

**THE ANALYSIS OF INDUSTRIAL LOCATION
OF FISH PROCESSING INDUSTRIES IN INDONESIA
BETWEEN 2000 – 2004**

TESIS

Diajukan sebagai salah satu syarat guna memperoleh gelar
Magister Sains Ekonomi
pada Program Studi Ilmu Ekonomi
Program Pascasarjana Fakultas Ekonomi Universitas Indonesia

DINARDANI RATRISARI
0606140730



UNIVERSITAS INDONESIA
FAKULTAS EKONOMI
PROGRAM PASCA SARJANA ILMU EKONOMI
DEPOK
DESEMBER 2008

PERPUSTAKAAN PUSAT
UNIVERSITAS INDONESIA

HALAMAN PERNYATAAN ORISINALITAS

Tesis ini adalah hasil karya saya sendiri,
Dan semua sumber baik yang dikutip maupun dirujuk
telah saya nyatakan dengan benar.

Nama : Dinardani Ratrisari

NPM : 0606140730

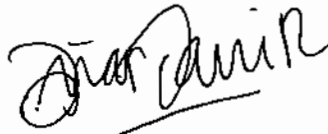
Tanda Tangan : 

Tanggal : Desember 2008

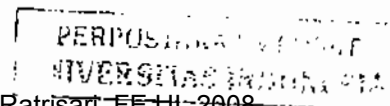

HALAMAN PENGESAHAN

Tesis ini diajukan oleh :
Nama : DINARDANI RATRISARI
NPM : 0606140730
Program Studi : Pasca Sarjana Ilmu Ekonomi
Judul Tesis : **THE ANALYSIS OF INDUSTRIAL
LOCATION OF FISH PROCESSING
INDUSTRIES IN INDONESIA BETWEEN
2000-2004**

Telah berhasil dipertahankan di hadapan Dewan Penguji dan diterima sebagai bagian persyaratan yang diperlukan untuk memperoleh gelar Magister Sains Ekonomi pada Program Studi Ilmu Ekonomi, Fakultas Ekonomi, Universitas Indonesia.

DEWAN PENGUJI

Pembimbing : Dr. Peter de Valk (Ttd terlampir)

Sekretaris Program Studi : Prof. Nachrowi Djalal ()
Nachrowi, Ph.D

Ditetapkan di : Depok

Tanggal : Desember 2008

PERSETUJUAN THESIS

Nama : DINARDANI RATRISARI
N.P.M : 0606140730
Kekhususan : Economics of Development
Judul Thesis : The Analysis of Industrial Location of Fish Processing Industries in Indonesia Between 2000-2004
Pembimbing Thesis : Peter de Valk
Penguji Thesis : Michael Grimm

Depok, September 2008

Pembimbing Tesis,

Ketua Program Studi



(Dr. Peter de Valk)



ARINDRA A. ZAINAL Ph.D
NIP.131 473 822

**HALAMAN PERNYATAAN PERSETUJUAN PUBLIKASI
TUGAS AKHIR UNTUK KEPENTINGAN AKADEMIS**

Sebagai sivitas akademik Universitas Indonesia, saya yang bertanda tangan di bawah ini:

Nama : Dinardani Ratrisari
NPM : 0606140730
Program Studi : Pasca Sarjana Ilmu Ekonomi
Fakultas : Ekonomi
Jenis karya : Tesis

Demi pengembangan ilmu pengetahuan, menyetujui untuk memberikan kepada Universitas Indonesia **Hak Bebas Royalti Noneksklusif (*Non-exclusive Royalty-Free Right*)** atas karya ilmiah saya yang berjudul:
The Analysis of Industrial Location of Fish Processing Industries in Indonesia Between 2000-2004

Beserta perangkat yang ada (jika diperlukan). Dengan Hak Bebas Royalti Noneksklusif ini Universitas Indonesia berhak menyimpan, mengalihmedia/formatkan, mengelola dalam bentuk pangkalan data (*database*), merawat, dan mempublikasikan tugas akhir saya tanpa meminta izin dari saya selama tetap mencantumkan nama saya sebagai penulis/pencipta dan sebagai pemilik Hak Cipta.

Demikian pernyataan ini saya buat dengan sebenarnya.

Dibuat di : Depok
Pada tanggal : Desember 2008

Yang menyatakan

(Dinardani Ratrisari)

Universitas Indonesia

ABSTRAK

Nama : Dinardani Ratrisari
Program Studi : Ilmu Ekonomi
Judul : The Analysis of Industrial Location of Fish Processing Industries in Indonesia Between 2000-2004

Pada umumnya, industri akan memilih lokasi usaha yang paling optimal untuk, meningkatkan produktifitas dan produk yang dihasilkannya. Hal yang sama berlaku juga pada industri pengolahan perikanan di Indonesia, yang secara dominan tersebar di Propinsi Jawa Timur dibandingkan dengan propinsi lainnya. Untuk itu, tesis ini akan menganalisis keunggulan Propinsi Jawa Timur dalam mengalokasikan industri pengolahan hasil perikanan and mengekspor produk perikanan dibandingkan dengan Propinsi Sulawesi Selatan. Selanjutnya, tingkat konsentrasi industri pengolahan hasil perikanan di Indonesia dan Jawa Timur selama tahun 2000 hingga 2004 akan diukur menggunakan Koefisien Gini, sedangkan faktor-faktor utama penentu lokasi industri pengolahan hasil perikanan di Indonesia akan diukur dengan menggunakan Panel Data Model.

Dari hasil penelitian, terungkap bahwa keberadaan pusat-pusat industri, fasilitas transportasi, institusi keuangan, dan peningkatan permintaan komoditas perikanan dari pasar domestik, merupakan faktor-faktor yang memicu pertumbuhan industri pengolahan hasil perikanan dan peningkatan ekspor produk perikanan dari Jawa Timur. Merepresentasikan tingkat konsentrasi industri pengolahan perikanan, jumlah pekerja pada industry ini tersebar sangat tidak merata antar propinsi selama tahun 2000-2004. Hal ini ditunjang dengan hasil regresi panel data yang menunjukkan bahwa nilai share produk/output sektor perikanan, rata-rata intensitas jumlah pekerja pada industri pengolahan perikanan, dan keberadaan pelabuhan perikanan merupakan faktor-faktor yang signifikan mempengaruhi konsentrasi industry pengolahan perikanan di suatu propinsi, yang direpresentasikan oleh share jumlah pekerja pada industry ini terhadap total pekerja di tingkat nasional.

Kata kunci:

Industri Pengolahan, konsentrasi, koefisien Gini, lokasi industri

ABSTRACT

Name : Dinardani Ratrisari
Study Program : Graduate Program in Economics
Title : The Analysis of Industrial Location of Fish Processing Industries in Indonesia Between 2000-2004

Generally, industries choose to allocate their firms in specific locations which are conducive to increase their productivity and economic outputs. This paper is investigating three major points related to the development of fish processing industries in Indonesia. First, the analysis about the prominent role of East Java in allocating the fish processing industries and exporting fishery products compared to South Sulawesi. Second, the analysis about the concentration degree of fish processing industries in Indonesia and East Java, measured by Locational Gini Coefficients, and the analysis about their trends during 2000-2004. Third, the analysis about the factors which affect the industrial location of fish processing industries in Indonesia.

This research reveals the fact that the allocation of fish processing industries in Indonesia is triggered by other crucial factors, namely the historical aspects and particular local policies which are conducive to the development of fishery sector, rather than merely affected by the presence of natural resource endowments. Furthermore, the paper concludes that the distribution of employment working on fish processing industries in national level were extremely unequal across provinces, whereas the distributions of total employment were moderately unequal across provinces from 2000 until 2004. Coexisted with this finding, the result from panel data regression exposes that the share of output from fishery sector, the average intensity of employment working on fish processing industries, and the availability of fishing ports are the significant factors affecting the concentration of fish processing industries in a certain province, which is in our model, represented by the share of employment working on these industries to the total national employment.

Keywords

Processing industries, concentration degree, locational gini coefficient, industrial location

DAFTAR ISI

HALAMAN JUDUL.....	i
HALAMAN PERNYATAAN ORISINALITAS.....	ii
HALAMAN PENGESAHAN.....	ii
HALAMAN PERNYATAAN PERSETUJUAN PUBLIKASI TUGAS AKHIR UNTUK KEPENTINGAN AKADEMIS.....	iv
ABSTRAK.....	v
DAFTAR ISI.....	vii
DAFTAR TABEL.....	viii
DAFTAR GAMBAR.....	ix
DAFTAR LAMPIRAN.....	xi
1. INTRODUCTION.....	1
1.1. Background.....	1
1.2. Policy Relevance and Justification.....	3
1.3. Paper Objective.....	5
1.4. Hypothesis.....	6
1.5. Scope of Work.....	6
1.6. Research Constraints.....	7
1.7. The Structure of the Paper.....	7
2. THEORETICAL FRAMEWORK.....	8
2.1. Industrial Location.....	8
2.2. The Fish Processing Industries in Indonesia.....	11
2.3. The Concentration Measurement.....	12
2.3.1 The Description.....	12
2.3.1 The Empirical Research.....	14
3. METHODOLOGY.....	17
3.1. Qualitative Analysis.....	17
3.2. Quantitative Analysis.....	17

3.2.1 Concentration Index.....	17
3.2.2 Panel Data Model	18
3.2.3 Data Issues	22
4. FINDINGS AND ANALYSIS.....	25
4.1. Qualitative Analysis.....	25
4.1.1 The Major Differences Between East Java and South Sulawesi ...	25
4.1.2 The Inter-regional Fishery Trading	47
4.2. Qualitative Analysis.....	50
4.2.1 The Concentration Measure.....	50
4.2.2 Panel Data Model	53
4.2.3 Summary of Analyses.....	55
5. CONCLUSION.....	57
REFERENCES.....	60
ANNEXES.....	65

DAFTAR TABEL

Table 4.1 The Approved Investments (Foreign and Domestic) in Total Sector and Fishery Sector in East Java and South Sulawesi, 2000-2004	31
Table 4.2 Number of Fish Processing Industries and Workers Engaged In These Industries in East Java and South Sulawesi, 2000-2004.....	32
Table 4.3 The Operational Activities in Tanjung Perak Port and Makasar Port.....	41
Table 4.4 The Locational Gini Coefficient at National and East Java Level, 2000-2004	50
Table 4.5 The Panel Data Result.....	vii

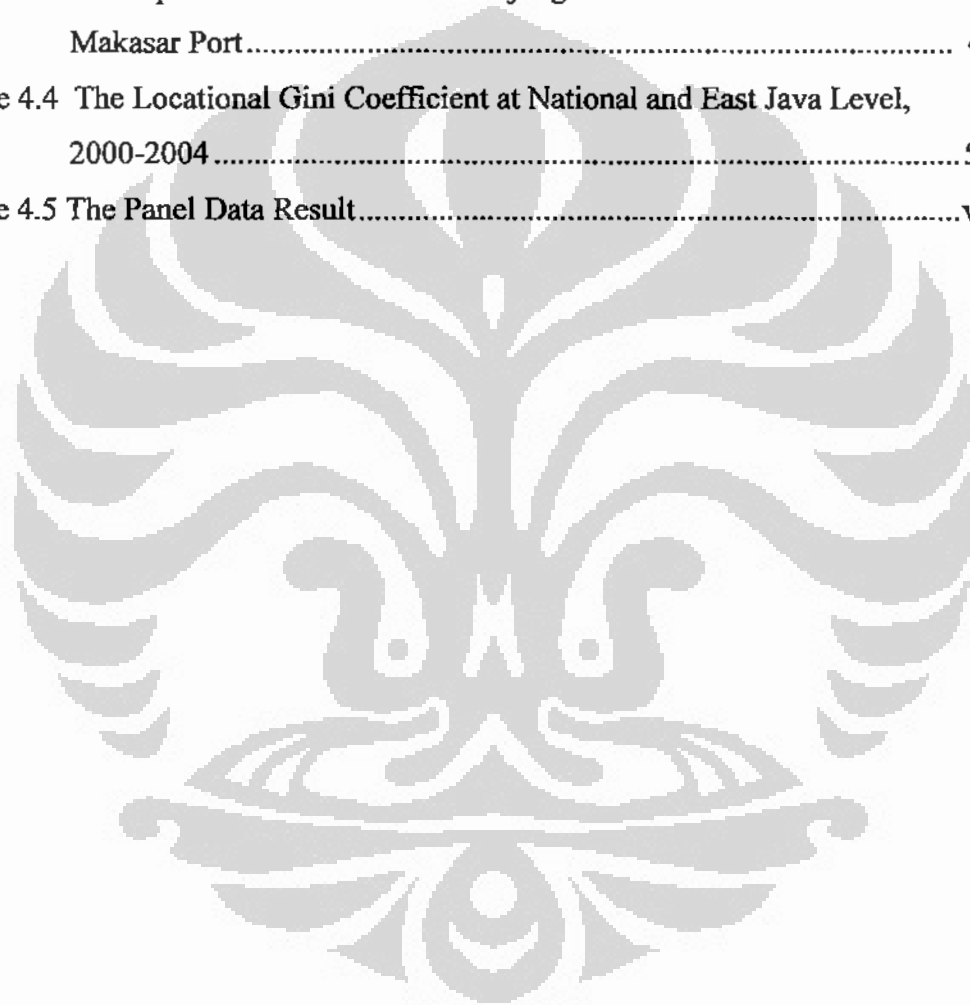

DAFTAR GAMBAR

Figure 4.1 Indonesian Map.....	28
Figure 4.2 The Division of Main Growth Corridors in East Java.....	35
Figure 4.3 Export Growth Between Provinces (Year on Year Growth)	42
Figure 4.4 Import Growth Between Provinces (Year on Year Growth)	42
Figure 4.5 The Loading and Unloading Activities in Makassar Port (Year on Year Domestic and International Export Import).....	43
Figure 4.6 The Supply Chain Activities of Fishery Commodities From East Java.....	44
Figure 4.7 The Distribution Chains of Fishery Commodities.....	48
Figure 4.8 The Trading Chains of Fishery Commodities in East Java	49

DAFTAR LAMPIRAN

Annex I Hirschman-Herfindahl Index (HHI).....	
The Location Quotient (LQ).....	
Plotting The Locational Gini Coefficient Area	
Problem of Multicollinearity	
The Hausman Test	
Annex II a Total Production of Fishery Commodities by Province, 2000-2004.....	
b Number of Fish Production in East Java and South Sulawesi, 2000-2004	
c The Volume of Marine Fishery Products by Type of Production	
d The Volume of Inland Open-water Fishery Products by Type of Production.....	
e Export Volume of Fishery Products by Province, 2000-2004	
f The Volume and Value of Export and Import of Fishery Commodities in East Java and South Sulawesi, 2000-2004	
g Export Volume and Value of Fishery Products Based on Type of Commodities in East Java and South Sulawesi, 2003-2004	
h The Composition of Exports from East Java, 2002 and 2004.....	
i The List of Exporting Companies in East Java.....	
j The List of Exporting Companies in South Sulawesi	
k Export Commodity of South Sulawesi, 2001-2002	
l The Value of Export Commodity of South Sulawesi, 2003-2004	
m Number of Fish Processing Firms by Province, 2000-2004	
n Number of Person Engaged in The Fish Processing Industries by Province, 2000-2004.....	
o The Distribution of Fish Processing Firms by Regencies in East Java, 2000-2004.....	

p	The Summary of Major Differences Between East Java and South Sulawesi.....
Annex III A	The Panel Data Regression of Fixed Effect Model
B	The Panel Data Regression of Random Effect Model
C	The Hausman Test
D	Testing The Correlation Between Dependent and Independent Variables.....
E	Testing The Autocorrelation and Heteroskedasticity
Annex IV	The Dependent and Independent Variables Used in The Panel Data Regression

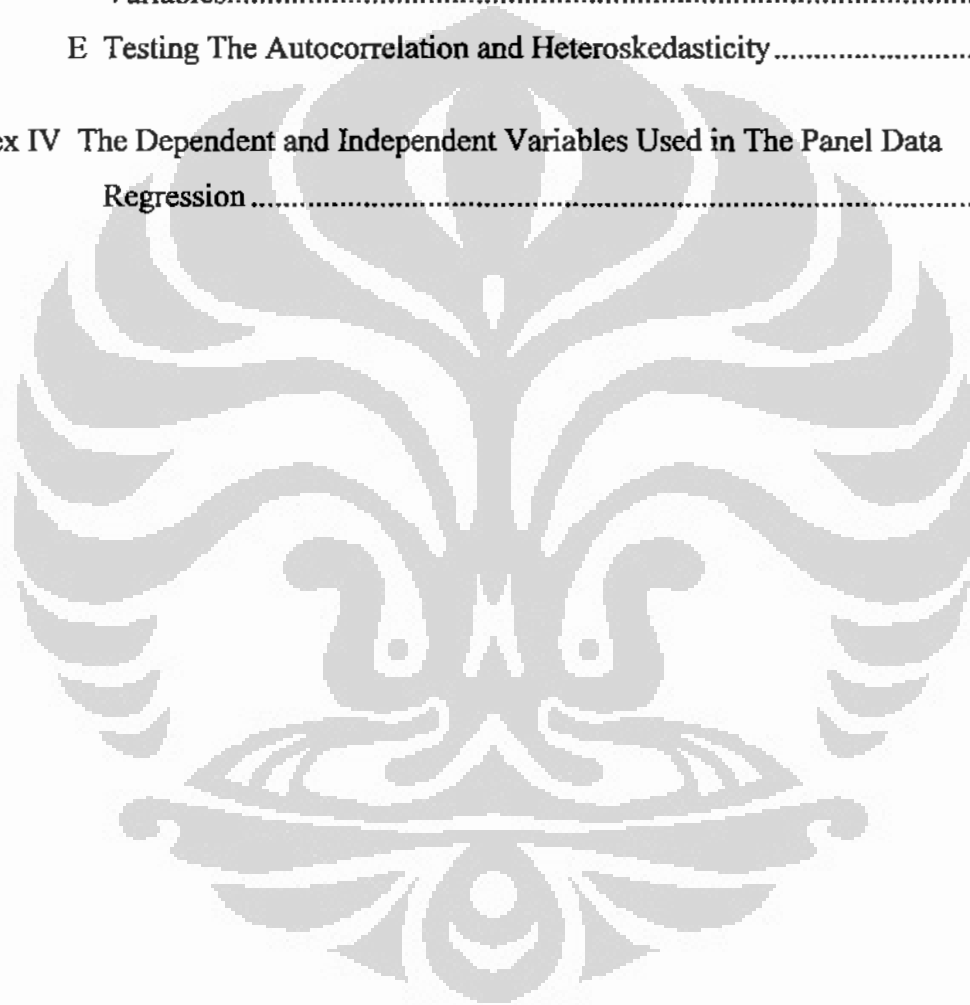

CHAPTER 1 INTRODUCTION

The objective of this paper is to analyse the factors underlying the major differences of East Java and South Sulawesi in allocating fish processing industries in Indonesia. Based on the presumption that most of these industries are located in East Java, we also want to analyse the important factors underpinning the supremacy of East Java in allocating the fish processing industries there, compared to South Sulawesi. Hence, the Locational Gini Coefficient (LGC) is applied to measure the concentration degree of fish processing industries in Indonesia and East Java, and then, used it to analyze the trends of LGC in national and East Java level in 2000-2004. Lastly, the panel data model is used to examine the factors which affect the industrial location of fish processing industries in Indonesia.

1.1 Background

One important decision for entrepreneurs who consider starting a new firm is to decide where to locate their business (Nyström 2005). All economic activities taking place within geographical space may differ related to the characteristics of firms' and various regions in which the firm could locate (McCann 2001). There are two types of location decisions chosen by industries; industrial agglomeration, and industrial dispersal.

In order to increase the productivity and to enhance economic outputs, the industrial agglomeration is chosen by firms regarding to the product's quality, physical distance and transportation costs. By agglomerating, spatial spillovers and co-operation of economic activities can occur not only within firms in the same industry, but also in the different industries. Meanwhile, the industrial dispersal represents the distance characteristics of individual transactions by producers and consumers in which the market prices are assumed differently at all locations¹. This pattern commonly exhibits in the primary industries which

¹ Ibid.

manage and produce the output whose raw materials coming from natural resources, such as agricultural, fishery, and forestry.

The fish processing industries researched in this paper refer to the fish processing activities delivered by fisheries to supply the fish products industry, which is, in industrial terms, similar to the seafood products industry. The products of these industries are usually sold wholesale to grocery chains, to intermediaries, or even to be exported. Meanwhile, the products of these industries are ranging from canned fish, salted/dried fish, smoked fish, frozen fish, processed fish, to the manufactured and preserved fish products as well as to other seafood products.

Reviewing the Gross Regional Domestic Product (GRDP) by fishery sector, the statistical figure shows that in 2000-2004, the shares of GRDP by fishery sector from East Java and South Sulawesi to the national level were the highest among other provinces. The share of East Java to the national Gross Domestic Product from this sector increased from 11.21% to 12.77%, while the share of South Sulawesi slightly decreased from 9.82% to 8.82%. These values were greater than the average yearly share of GRDP by fishery sector in the same period (3.33%). Somehow, these figures indicate the significant role of these provinces in developing the marine and fishery sector in Indonesia.

The role of East Java has been recorded significantly in collecting and exporting fishery products to foreign and domestic markets, and allocating the fish processing industries within this province. The data shows that during this period, East Java became the largest fish producing province followed by South Sulawesi. In fact, the role of East Java in exporting the fishery commodities has surpassed other important fish producing and fish exporting provinces, which are South Sulawesi and DKI Jakarta, respectively. Of 512 fish processing firms existed in all 27 provinces in 2000, around 39.26% was located in East Java, and despite the total number of these firms declined to 466 firms in 2004, 34.55% of these firms was still present in this province. In addition, 35.6% of total employment working on fish processing industries was also distributed in East Java in 2000, but it declined to 26.4% in 2004.

Initially, East Java's pioneer industries were established in the early mid 19th century to serve an emerging plantation economy (Dick 1995). This phase was then continued by the booming of industrialization in East Java from early 1980s onwards, while at the same time, the rapid growth of manufacturing industries was complemented by the position of Outer Islands in becoming a significant increment to the adjacent 'captive' market of East and Central Java (Dick et al. 1993).

Hence, it is very interesting to investigate which factors relevantly form East Java to be more attractive in allocating fish processing industries than any other provinces. We presume that such particular policies has been predominantly determining the considerable position of East Java and South Sulawesi, in which they perform as incentives for private sectors to allocate the industries there, rather than merely the presence of natural endowments of fishery resources. Particularly, the high number of fish processing industries and the employment working on these industries also improve the development of marine and fishery sector in East Java.

Finally, this paper uses the Locational Gini Coefficient to measure the concentration degree of fish processing industry in Indonesia and East Java, based on the share of geographical distribution of employment working on fish processing industry across 27 provinces and 19 regencies in East Java corresponding to the share distribution of the aggregate employment in national and East Java level, respectively. Jointly with this finding, we also analyse the trend of Locational Gini Coefficients in the national and East Java level from 2000 until 2004. In the end, complemented by the qualitative analysis of East Java and South Sulawesi in particular, the panel data model is used to examine the factors which affect the industrial location of fish processing industries in Indonesia.

1.2 Policy Relevance and Justification

The basic concept of the industrial location within fish processing industries should be based on several factors, namely the marine and fishery resources within each province, the government's support through provisioning sufficient infrastructures and transportation modes, as well as the knowledge-spillovers

Universitas Indonesia

between every player engaged in these industries. Complemented with the felicitous capabilities fishery communities in managing fishery resources, the proportionate gain derived from the development of fishery sector within regions, somehow, will be achieved.

In contrast to other countries in which the fishing industries are concentrated in particular areas, the fish processing industries in Indonesia have shown the tendency to be unequally distributed across provinces regarding to the natural resources possessed by each province. This fact, then, leads to the question about which factors affecting the fish processing industries in allocating their firms distinctively.

Yet, having had a non-integrated industry in a particular location, the fish commodities from larger producing provinces are commonly transported across islands to capture broader domestic and international markets, besides acquiring the local markets. In that sense, the reasons why particular markets are located at particular places are also economic questions (McCann, 2001). Seemingly, the paradox of these industries benefitting from their dispersed location is due to the initial condition of marine and fishery endowments and the professional vein in managing these industries in each region.

Based on the preliminary study done for East Java, it has observed that one of the specific characteristics of the civil services of East Java lies on their commitment to make an independent decision-making². Even within its provincial government, the decision-making has been professionalized in the way that the governor has formed a think tank of specialists in the governor's office to assist in the formulation, coordination, and monitoring of policies.

While officials in East Java can certainly be zealous in implementing national policies, the presumption is nonetheless that national policies need to be tailored to local needs and conditions and do not preclude simultaneous local initiative. Generally, inappropriate national policies are never resisted outright, but fitted into goals and strategies forged at the provincial level, but apparently,

² In other provinces, and most notably in West Java, officials are appointed primarily for their loyalty to Jakarta and their willingness to implement central government policies. Their success is judged by their ability to placate regional interest rather than in serving them.

East Java has been far enough away from Jakarta for this to be tolerated by the central government ((Dick et al. 1993).

Indeed, the historical factor of locating central government in Java from the colonial era, somehow, gave an important impact to East Java's superiority in constructing the physical infrastructures to be far superior so that firms were encouraged to locate there (Kuncoro 2002). Meanwhile, Makassar, a capital of South Sulawesi, had also been known as a major trading centre, an entrepôt linking eastern and western Indonesia in the early 17th century.

The connection between Makassar and Surabaya, a capital of East Java, was established in 1891 by the Dutch foreign shipping company, through re-routing its service via Surabaya and increasing the number of sailings due to its role in channelling imports from eastern parts of Indonesia, and exporting directly goods for these parts bypassing Makassar. Moreover, despite the production of fish commodities are widespread in almost all provinces, and even located in remote areas, there is a red thread connecting these provinces with East Java and South Sulawesi through the fish trading activities.

All these preliminary facts and figures, somehow, intertwine the inter-sectoral overviews which underlie the analysis of East Java and South Sulawesi's engagement in developing the marine and fishery sector in Indonesia. To analyze the prominent role of East Java in allocating fish processing industries and collecting fish commodities from other regions, there are several aspects that should be comprehended regarding to the historical background, local policies, and the development phases of East Java. Altogether with its superiority in provisioning better infrastructures and facilities, these aspects have been considered as significant determinants in accelerating the economic growth of East Java.

1.3 Paper Objective

The main objective of this research is: to analyse the factors underpinning the supremacy of East Java in collecting and exporting fishery products compared to South Sulawesi.

The sub-objectives of this research are:

1. To analyse to local government policies of East Java and South Sulawesi provinces which promote the concentration of fish processing industries.
2. To analyse the inter-regional trading pattern of fishery products among provinces in Indonesia.
3. To measure the Locational Gini Coefficient in order to analyze the concentration degree of fish processing industries in Indonesia and East Java, based on the geographic distribution of employment working on the fish processing firms across 27 provinces and across 19 regencies in East Java in 2000-2004.
4. To analyze the trend of Locational Gini Coefficient in national and East Java level from 2000 until 2004.
5. To construct the model which examines the factors affecting the industrial location of fish processing industries across provinces.

1.4 Hypothesis

The important factors underpinning the supremacy of East Java as the main gateway for collecting and exporting fishery products compared to South Sulawesi are:

- a. The interregional trading linkage of fishery commodities between East Java and other provinces;
- b. Industrialization booming in East Java as a major factor of the high economic growth rate of this province;
- c. The policy instruments of local government through the provision of industrial zones, good infrastructures, and transportation facilities.
- d. The highest number of fish processing industries and people engaged in these industries.

1.5 Scope of Work

The research in this thesis uses the secondary data from the Ministry of Marine Affairs and Fisheries and the Central Bureau of Statistics, Indonesia. All fishery data used are yearly provincial data in 2000 – 2004. The variables used in this paper are:

- The local government policies in East Java and South Sulawesi which encourage the investment in fish processing industries.
- The number of total employment and the employment working on the fish processing industries in each province;
- The GRDP by fishery sector based on year 2000 constant price in 27 provinces and the national level;
- The number of supporting facilities and infrastructures;
- The volume and value of marine fisheries and aquaculture production, for fresh and preserved commodities, by provinces;
- The export and import volume of fishery products by provinces;
- The number of fish processing firms by province in 2000- 2004.

1.6 Research Constraints

1. The time series data used in this research covers the period in 2000 – 2004, because the data for the recent years are not available yet.
2. We make several assumptions to simplify the analysis of factors affecting the industrial location of a particular industry by using the panel data.

1.7 The Structure of the Paper

The paper consists of five chapters, comprising the introduction, the theoretical framework, the methodology, the findings and analyses, and will be ended by the conclusion. The analysis part captures the qualitative and quantitative analyses. First, to analyse the major differences between East Java and South Sulawesi which underpin the primary role of East Java in collecting and exporting fishery commodities as well as allocating fish processing industries. Second, the Locational Gini Coefficient is applied to measure the concentration degree of fish processing industries, in which its trend in national and East Java level from 2000 – 2004 will be observed as well. The panel data analysis will focus on the factors affecting the industrial location fish processing industries in Indonesia. In chapter five, the conclusion will be presented based on all findings and analyses of the research.

CHAPTER 2

THEORETICAL FRAMEWORK

The decision for an industry to allocate its location cannot be separated from many factors which determine on how the location fulfils the industry's requirements. This chapter reviews the typical of industrial location and all factors which are important in determining the existence of industrial concentration based on the theories and some empirical researches.

2.1 Industrial Location

Alfred Marshall was one of the first economists who initially inscribed the concept of clusters by pointing that the advantages of being clustered are related to the availability of skilled labour and intermediate goods suppliers as well as related to the transmission and discussion of new ideas or improvements (Marshall 1920). A series of more modern studies have adapted Marshall's thoughts to consider a number of economically relevant factors that can influence the concentration of industries, like the following:

- Transportation costs (Ellison and Glaeser 1997, M. Fujita et al. 1999, Neary 2001);
- Density of and investment in transport infrastructure networks (Krugman 1991a, Martin and Rogers 1995);
- Role of ports in facilitating international trade and industry activity (M. Fujita et al. 1999, M. Fujita and Mori 1996);
- Resource endowments (Head et al. 1995);
- Technology spillovers (Audretsch and Feldman 1996, M. Fujita and Thisse 1996, Porter 1990);
- Specialisation of labour (David and Rosembloom 1990);
- Linkages between industries in terms of intermediate inputs (Krugman 1991b);
- Location fundamentals and their role in enabling cities to revert to their long term growth path even after major shocks (Davis and Weinstein 2002);

- Agglomeration of population and technological economies of scale in production and consumption in terms of cities.

Furthermore, the cluster model proposed by Krugman (1991) views the power of push and pull forces in determining the spatial preferences of the industries and the degree of their concentration in the region. The factors which lead to industrial concentration are market size, labor market depth and pure externalities; whereas the pull forces, which lead to industrial dispersion, are immobility of factors of production, high rents and pure external diseconomies (Krugman 1991a). He also argued that, while cost and other factors are important, historical events and accident can result in certain activities initially taking place in particular areas for non-economic reasons.

Basically, cluster policies enable local regions to build those special linkages and gain those intangible assets of knowledge, brand and reputation, which enable them to compete in the world market. By adding diversity, partners' strengths can compensate for others' weaknesses, which enable a more comprehensive range of activity. Firms can benefit from locating near to similar or different industries because of co-location externalities which arise through the labour market, technology spillovers, and shared infrastructures.

The industrial clustering can be developed through the integration of complementary activities, both within or across sectors, which may vary across locations regarding to the establishment size, plant's turnover, productivity, and specialization. But, factors that do not vary across geographic locations, such as firm and industry characteristics, will only affect the location choices to the extent that they affect firms' sensitivity to other factors.

On the contrary, the conditions for agglomeration economies will typically not occur in which: 1) the level of technological sophistication is low; 2) there are a limited degree of specialization and few indivisibilities, and; 3) high transportation costs, (Tveteras 2001). Moreover, the preference of being dispersed is also determined by the relationship between industrial linkages and the nature of the products being transported (McCann 2001).

The industrial dispersal commonly exhibits in the primary industries which manage and produce the output whose raw materials coming from natural

resources, such as agricultural, fishery, forestry, and mining. It is very common that the agricultural and fishery activities tend to be distributed evenly over space, because of the requirement of land and water (deep-water and mid-water) as inputs to the production activities.

In general, the fish processing industries in Indonesia exist in different regions or provinces by producing and processing fishery commodities from these regions or others, which in turn, forming the inter-regional trading activities. Relating to the inter-regional economy, in which both capital and labour are mobile, the only production factor inputs which are location-specific are natural raw material inputs, land, and local infrastructure inputs³.

These statements are in line with the theories proposed by Holmes and Stevens (2004), stating that the natural advantage, and the government policy are among the factors which also affect the industrial location (Thomas J. Holmes and Stevens 2004). The former affects the location of industry in the way that innate physical attributes are different in each location, and they may cause the specialization of industry in a specific location. In other words, the distribution of industries can be different among regions adjusted to the needs of these industries for the physical attributes owned by each region to support their production activities. These attributes includes the elements such as topographical features, climate, soil, and access to deep water ports.

In the local context, the latter one is interpreted as the significant government policies which may differ from one region to another, but having an influential role in affecting the location of industries. These local policies could play a major role in developing the local industrial base within each province, and then, as the productivity and output increased, this causes the local revenues to be increased as well. Apparently, the government's policies applied in each region also strongly influence the economy and the attractiveness of each region for investments. Although the two regions are initially identical, a slight advantage given to one region in the form of a benevolent government policy, for example: tax subsidies, may trigger a sharp rise in inequality between these regions (Krugman 1991a, 1991b).

³ Ibid.

To see the effectiveness and the implication of these policies in our research, the proxies that are used here are the number of industries existed within a region and the amount of exports from this region. In addition, the regions and cities which close to the natural resources or natural advantages such as nearness to rivers, coasts, and transportation networks are presumed to benefit more likely from external trade whereas those in remote areas are not.

As widely discussed in literature, the infrastructure, as one element of transportation input in the production activity, has a key role in pertaining the existence of industries. In fact, the well-performing infrastructures are strongly required to link one regional economy to other parts of the inter-regional economy (Vickerman 1991). This type of input is regarded as the crucial input to almost all industrial and commercial activities, despite the type of goods or people being transported. Therefore, by using the infrastructures within a region, the industries are able to reduce the transportation cost in delivering raw materials from and outputs to outer regions. Especially if the type of the industry is relatively mobile, the spatial variations in the transportation costs are regarded significantly in affecting the attractiveness of the region as the location of investment (McCann 2001).

The well-performing infrastructures also determine the productivity level of regional industries taking part in the inter-regional economy. This also applies to the provinces in our research, East Java and South Sulawesi which are among the provinces actively involved in the inter-regional fish trading activities. Hence, having had the regional policies to accommodate the existence and the improvement of local infrastructures is strongly required by each province in order to attract more investors.

2.2 The Fish Processing Industries in Indonesia

Indonesia has a diverse marine estate capturing both marine and inland capture fisheries, and a significant economic dependence on coastal and marine resources. These marine capture fisheries include coastal or offshore fisheries. By using small-scale boats as the fishing fleet, their fishing operations can be categorized as small-scale or commercial fisheries. Meanwhile, inland capture fisheries include

lakes, rivers, reservoirs and dams, in which almost all fishing units used are artisanal, subsistence and labour-intensive.

Approximately over 5 million people are directly involved in fishing and fish farming, and together with their families, they make up at least 4% of the total population. According to the household survey held by Central Board of Statistics, Indonesia, the net income of one fishery household in 2004 was 39.92 million rupiahs (4,465.90 US\$), mostly coming from marine and pond/paddy field fishing activities. In fact, the exports of fishery products have increased considerably since 1960s, in which the value of fishery exports was US\$ 1.61 billion in 1999 and increased to US\$ 1.78 billion in 2004.

In general, the fishing industry is comprised of two sectors: fishing and aquaculture. Fishing includes deep-water, mid-water and inshore activities, and is recognized as a hunting practice. Conversely, aquaculture is a farming activity (gathering), and involves the seeding, growing and harvesting of a variety of seafood. Within the marine and fishery industries does exist a vertical relationship between buyers and suppliers and a horizontal relationship between similar firms in the form of joint ventures, alliances or partnerships.

In relation to that, the fish processing industries can be subdivided into two major categories, which are: fish handling (which is initial processing of raw fish) and fish products manufacturing. Another natural subdivision is the primary processing involved in the filleting and freezing of fresh fish for onward distribution to fresh fish retail and catering outlets. The other one is related to the processing which produces chilled, frozen and canned products for the retail and catering trades in domestic and foreign markets.

2.3 The Concentration Measurement

2.3.1 The Description

The geographic concentration is the outcome of a life cycle process in which new plants are constantly being born, existing plants are expanding and contracting at different rates, and a substantial number of businesses are failing (Dumais et al. 2002). Basically, the concentration is referred to as an a-spatial concept of variability which can be measured with various tools in order to analyze the

spatial distribution of economic activities, and it can be directly obtained from the densities of production at each location, so borders do not play a crucial role (Lafourcade and Mion 2004).

Among the various measures of industry concentration, the Locational Gini Coefficient (LGC) and Hirschman-Herfindahl index (HHI) are the standard common measures to be used, while the Ellison and Glaeser (EG) index is more sophisticated one. The HHI as the simplest measure is used to address the geographic dispersion and uneven distribution of employment within sub-regions of an area under study, assuming that all sub-regions have the same area and it is sensitive to the number of firms in each industry⁴ (Bieri 2006). Meanwhile, Ellison and Glaeser (1997) spell out two forces of spatial concentration: natural advantages and spillover effects among neighbor plants producing the same kind of goods. However, the parameters corresponding to these forces are observationally indistinguishable, and only a linear combination of them can be estimated⁵.

Developed by Corrado Gini (1912), the Gini coefficient was as a summary measure of income inequality in society, usually associated with the plot of wealth concentration, introduced earlier by Max Lorenz (1905)⁶. Proposed by Krugman (1991), LGC is a modification of the Gini inequality index where individuals are replaced by regions and weights are given by the regional shares in total population or employment (Krugman 1991a).

The LGC accounts for agglomeration and concentration within a specific region, but in a most sophisticated way than the HHI. Just like the Gini coefficient, the locational counterpart measures the extent to which geographic activity is concentrated. In terms of industry concentration, LGC is referred to as a *relative* measure of industry concentration as distinct from an absolute measure such as the Herfindahl Index (Fedderke and Szalontai 2005). As the most widely used measure of industrial concentration in the literature of the new economic

⁴ The Hirschman index is not considered further in this research because of its limited application compared to LGC, and the unavailability of firm-level market share data for the fish processing firms.

⁵ Consequently, it is impossible to directly disentangle resources-driven from externalities-driven concentration. A major drawback of this index is that it is also not suitable for international comparisons because it is very sensitive to the level of aggregation of regional data.

⁶ See Annex A for further explanation.

geography, the LGC is the ratio of the mean of the difference between individual LQs⁷ and the mean LQ (Bieri 2006). Essentially, by using the Gini and Lorenz curves, we can observe deeply that:

- Looking at the spatial variation in terms of inequality is possibly an effective approach for extension purposes. There is a general familiarity with the concept of wealth inequality, or others, which describe a small percentage of the population having a disproportionate share of the aggregated society income.
- The sharing of analytical tools might provide new linking points between site-specific management and other disciplines, which have well developed frameworks for dealing with inequalities (Sadras and Bongiovanni 2004).

The value of Gini coefficient ranges from 0, when all units are equal, to a maximum of 1 in an infinite population in which all units but one yield 0 (Weiner and Solbrig 1984). Zero value implies that an industry is allocated across space in exactly the same way as total employment, while the industry is completely concentrated in one location (depending on the size of the industry itself), when the value is close to one (Lovely et al. 2002).

In order to get an optimal use of Gini coefficient, we need to have more observations or categories so that our result will be more reliable for assessing inequality. Only based on few observations is unreliable for comparing different groups at any one time, but can be reasonable for monitoring changes in inequalities over time. In comparing Gini coefficients, particularly over time, it is likely that the Gini coefficient is insensitive to multiplying all observations by a constant, but it is sensitive to adding a constant to all observations.

2.3.2 The Empirical Research

Several researches have been done to analyse what factors affect the phenomenon of industries being concentrated in a specific location, by using the Ellison Glaser index as the dependent variable in the panel data model. Meanwhile in our research, the dependent variable will be the share of employment working on fish

⁷ The location quotient (LQ) is the standard measure of employment distribution that controls for the size of the region, and see the annex for further explanation.

processing industries within each province to the aggregate national employment. But, the idea behind all these researches is the same, which is to investigate and analysis the determinants which significantly influence the decision of a particular industry to be concentrated or not, based on the theories and intuitive arguments.

One empirical research done by Kathuria and George (2005) over 66 manufacturing industries has investigated the important factors influencing the spatial location of manufacturing industries in 21 major states in India (Kathuria and George 2005). The factors that are used in this research are those that are associated with the agglomeration externalities and those that comprise natural and cost advantages. The natural and cost advantages are represented by the state domestic product, infrastructure availability, kind of governance and labour unionism; whereas existence of firms in a particular industry type indicates the presence of innovation spillovers⁸.

The result shows that the innovation spillovers and the infrastructure variables are highly significant in affecting the industries to agglomerate, while the labor unionism variable, represented by a number of disworker and dispute, gives the negative effect to the industrial cluster. Similarly capital invested indicates larger possibilities of spillovers, and hence, agglomeration; and it is also shown that a rich state (measured by its state domestic product) is likely to attract more industries.

Carrying out at three levels of administrative zones: zipcode, county and state, Rosenthal and Strange (2001) have estimated the determinants of agglomeration for the U.S. manufacturing industries using the EG index as a measure of agglomeration. The result shows that the labor market pooling has the most robust effect at all three levels⁹ (Rosenthal and Strange 2001). Another study is also done by Resende and Wyllie (2003) for the Brazilian industries, by analysing the effects of local infrastructures and local incentives to the agglomeration. They found out that the former has positive effects, while the latter is insignificant in affecting the location decision. However, the result concluded

⁸ Ibid.

⁹ Labour market pooling is a phenomenon where clusters of firms create a pooled market for workers with highly specialized skills that are required by these firms (Krugman, 1991). Such a market works to the advantage of producers (less labor shortages) as well as workers (less unemployment).

that the input utilization and knowledge spillovers appear to have positive impact on agglomeration (Resende and Wyllie 2001).

Regarding to the data availability of employment working on the fish processing industries and the specification of the concentration measure which is suitable to our objectives, thus, the Locational Gini Coefficient is chosen as the proper measure to examine the concentration degree of fish processing industries in Indonesia and East Java level. Especially, if we notice that the LGC is easier to apply in measuring the variability in regional concentration for a given industry.

Finally, based on the empirical researches done before, the panel data model has been widely used in several researches to investigate the factors affecting the concentration of industries in a particular location. Thus, as being described in the following chapter, this paper is also using the panel data to examine the factors which affect the industrial location of fish processing industries in Indonesia. In relation to that, the share of employment working on fish processing industries within each province to the total national employment is used as a proxy to measure the concentration of fish processing industries across provinces.

CHAPTER 3 METHODOLOGY

This chapter discusses the methodology used in this research. It starts from the qualitative method in analysing the factors which contribute to the difference between East Java and South Sulawesi in pooling and exporting the fishery commodities. Afterwards, the quantitative method is used to measure the concentration degree of fish processing industries using the Locational Gini Coefficient. Based on the value of this coefficient, we build the panel data model to examine the important factors which affect the industrial location of fish processing industries in Indonesia during 2000-2004.

3.1 Qualitative Analysis

This type of analysis is used as a method to analyze the significant factors which contribute to the difference between East Java and South Sulawesi in pooling and exporting marine and fishery products in Indonesia during 2000-2004. The analysis will capture the following points:

- The factors underpinning the supremacy of East Java in attracting the fish processing industries as well as pooling and exporting fishery products.
- The local government policies of East Java and South Sulawesi provinces which promote the concentration of fish processing industries.
- The inter-regional trading pattern of fishery products between East Java and other provinces in Indonesia.

3.2 Quantitative Analysis

3.2.1 Concentration Index

The 'Industrial' Gini coefficient is the LQ-based index which is often used to measure the overall degree of an industry concentration within a set of different locations. More precisely, it measures the degree to which the percentage distribution of an industry employment across locations corresponds to the percentage distribution of the national employment across the same locations.

There are different methods to calculate the Gini, but, we are going to put a simple formula as shown below (Brown 1994, Lafourcade and Mion 2004). The LGC is then derived from ordering locations by increasing values of employment LQs and cumulating the S_i^s and X_i shares over the ordered locations, which is defined as:

$$\text{Gini} = 1 - \sum_{i=1}^M (X_i - X_{i-1}) (S_i^s + S_{i-1}^s) \quad (3.1)$$

Where:

$S_i^s = \sum_{j=1}^i s_j^s$ the cumulative share of employment working on fish processing firms in each province to the national employment working on these firms, in the ordered locations i

$X_i^s = \sum_{j=1}^i x_j$ the cumulative share of aggregate employment in each province to the national aggregate employment, in the ordered locations i

It takes values in the range $[0 ; 1]$. The value of 0 means that all locations share the same employment proportion of the industry s , while, the value of 1 refers to an extreme inequality, meaning that the whole industry employment is being concentrated in a single location.

3.2.2 Panel Data Model

In order to check the relationship and the significance of determinants which affect the industrial decision, we use the econometrical study by constructing a panel data model. Theoretically, the combination between time series data (period 2000 – 2004) and cross-section data (27 provinces) will give more comprehensive result rather than using only time series or cross-section data. It also allows us to extent the number of observation which gives positive effects to the estimation result, i.e. to enlarge the number of degree of freedom and reduce the possibility of multicollinearity between independent variables.

Using the share of employment working on fish processing industries across provinces to the national employment as the proxy variable in assessing the degree of concentration of fish processing industries, then, we use the values of this variable as the dependent variable and assume it to be correlated with the

external economies. By pooling all time series and cross section data that are used gives a result of 135 observations which form the following function:

$$Y_{it} = \beta_0 + \beta_1 X_{1it} + \beta_2 X_{2it} + \beta_3 X_{3it} + \beta_4 X_{4it} + \beta_5 X_{5it} + \beta_6 X_{6it} + \beta_7 X_{7it} + u_{it} \quad (3.2)$$

Where:

- i = 1, 2, ..., 27 (i stands for the i^{th} cross-sectional unit which denotes the cross section identifier)
- t = 1, 2, 3, 4, 5 (t stands for the t^{th} time period which denotes the time identifier)
- Y = the dependent variable (the share of employment working on fish processing industries to the national employment by province)
- X_1 = SGDPF (the share of GRDP by fishery sector to total GRDP by province)
- X_2 = EMPDENS (the average labor intensity working on the fish processing firms by province)
- X_3 = PROD (the volume of fish production (marine, inland open-water, and aqua-culture fisheries production) by province (tonnes))
- X_4 = PRESV-PROD (the volume of preserved and processed fish commodities of marine and inland open-water fisheries by province--tonnes)
- X_5 = INFRAREA (the road density (the total road length divided by land size of each province by province--km))
- X_6 = HARBOR (the total volume of goods loaded and unloaded coming from domestic and international markets by province--tonnes)
- X_7 = FPORT (the number of fishing ports by province--units)
- u_{it} = the error term

In our model, each cross-sectional unit (the province) has the same number of time series observations, which are 5 observations for each province. Before regressing the panel data, the model is built based on the linear relation between the dependent and independent variables instead of transforming the model into logarithm function. This is because of the weakness of the logarithm model which cannot be formed from the value of zero as being captured in the values of

dependent and independent variables in some provinces, such as ‘harbor’ and ‘presv-prod’.

Particularly, in the log transformation model, the slope of coefficient is used to measure the level of changing in the dependent variable as a result of the changing in the independent variables. In our case, we are not trying to measure the elasticity of the dependent variable on all independent variables, but it is trying to capture the basic concept of linier model, which is not limited by the changing of the independent variables, as it is based on the linier parameters and variables (Nachrowi and Usman 2006). Hence, the advantageous of using panel data model are listed as followed.

1. We can control the individual heterogeneity, in which the individual data such as firms or regions can be varied. Without controlling this heterogeneity, the data collected will be biased. In other words, it can control the unobserved heterogeneity which may constant over time.
2. The data panel can give more complete information, more varied, more efficient, and less multicollinearity¹⁰ between variables.
3. The data panel can be used to observe the dynamic of adjustment which can detect and measure the effects that cannot be done by the pure cross-section or time series model.

There are three models that can be used in the data panel model:

1. **The pooled model:** the model which combines or collects all cross-section and time series data, and then estimate the model by using the *Ordinary Least Square Method (OLS)*. By using this simple regression, it is likely that the model will suffer from the problem of the omitted variables, which possibly can be solved through controlling for more factors in a multiple regression analysis. But, still, many factors might be hard to control for (Wooldridge 2002).
2. **The fixed effects model (FEM):** the “fixed effects” refers to the fact that although the intercept may differ across provinces, each province’s intercept does not vary over time or *time invariant* (Gujarati 2003). The weakness of

¹⁰ See the annex A for further explanation

this model is on the condition when a larger number of individuals are able to reduce the number of degrees of freedom. In this model, we have to take into account the “individuality” of each province or cross-sectional unit by letting the intercepts vary for each province, but assuming that the slope coefficients are constant across provinces. Apparently, we also include the unobserved, time-constant factors which affect Y_{it} , and the unobserved, time-variant factors which affect Y_{it} . This is why the model above is called the unobserved effects model or a fixed effect model (Wooldridge 2002).

3. **The random effects model (REM):** in this model, there is a heterogeneity among individuals/provinces, but the individual effect refers to a group-specific random element in each group. Having called the Error Components Model (ECM), these components refer to the composite error terms within the model, which comprise two, or more, error components representing the cross-section, or individual-specific, error component, and the combined time series and cross-section error component. The individual error components are not correlated with each other and are not autocorrelated across both cross-section and time series units (Gujarati 2004). However, the appropriate method that is usually used to estimate the random effect model is *Generalized Least Squares* (GLS). Essentially, in this random effect model, all individuals have a common mean value for the intercept ($= \beta_0$), whereas the individual differences in the intercept values of each province are reflected in the error term ε_i .

After finding out the result from both fixed effect (FEM) and random effect model (REM), the next step that we should do is to test which model is more efficient and consistent in our case. The Hausman test¹¹ is used to evaluate the significance of an estimator versus an alternative estimator, and it also checks a more efficient model against a less efficient but consistent model to make sure that the more efficient model also gives consistent results.

Theoretically, we look into the underlying assumption that one makes about the likely correlation between the individual, or cross-section specific, error component ε_i and the X regressors. If it is assumed that ε_i and the X 's are

¹¹ See annex A for further explanations.

uncorrelated, ECM may be appropriate, but if ε_i and the X's are correlated, FEM may be appropriate (Gujarati 2004).

To interpret the result from Hausman test, we use the Chi Square statistical distribution and the degree of freedom of k , which represents the number of independent variables. If the statistical value of Hausman test is greater than the critical value, it means that Fixed Effect model is more appropriate than Random Effect model, and vice versa.

3.2.3 Data Issues

The most natural way to understand agglomeration economies is directly through estimating them using the production inputs, such as employment, land, capital, and materials (Rosenthal and Strange 2002). Since labour is regarded as one of the production factors, the increase in differences of labor endowments across the regions will cause the increase in the industrial concentration as well (Falcioğlu and Akgüngör 1999). As being concentrated, the cluster of industries also becomes the source of specialised labour pools since it provides flexibility and efficiencies for firms in seeking specialist skills in the market and also facilitates the technology transfer (David and Rosebloom 1990).

Here in our research, the labor input is preferred to be used as a proxy in measuring the industrial concentration because it is easier to apply regarding to the data availability of the employment working on fish processing industries in Indonesia. Thus, set as the dependent variable, the share of employment working on fish processing firms in each province to the national employment working on all sectors is used as a proxy variable in altering the concept of the concentration in the fish processing industries. Moreover, the explanatory variables which are going to be used in our model are selected based on following theoretical contexts:

- **The share of output from fish processing industries to the total output :** According to Holmes and Stevens (2002), the establishment size will be larger at the concentration of industries, and this result can be identified using a "size coefficient," which is equal to the ratio of the mean establishment size (measured in value of output) at a location, to the mean size in the sector

across the US (T. J Holmes and Stevens 2002). Hence, to represent this notion, the size of the share of output from fishery sector to the total sector is used as a proxy to measure the degree of concentration of the fishery industries in a particular location.

- **The average labor intensity** : following Rosenthal and Strange (2001), we adopt the idea of capturing the labor market pooling as one important controlling variable that affects industrial agglomeration. The basic idea is that labor-intensive companies have a higher incentive to be concentrated in order to share the advantages of labour pooling (Hong and Fu 2008). Here, the average labor intensity on the fish processing firms is used as a proxy to examine the labor market's impact to the concentration of fish processing industries, based on the division of the total number of employment working on fish processing firms to the number of fish processing firms in each province.
- **The production of fishery products and preserved fishery products** : this variable represents the availability of resource endowments which imply that many industries traditionally exist close to natural resources for the reason of their proximity to input sources (Head et al. 1995). Marine and fishery resources are also presumed to be one reason for fish processing industries to be concentrated in a particular region and close to these sources. This argument is represented by the volume of fish production and preserved fish commodities coming from marine, inland-openwater, and aquaculture fisheries in every province.
- **The infrastructure density** : this variable represents the availability of infrastructure in supporting the concentration of industries (Krugman 1991a, Vickerman 1991). The industries are benefitting from the supply of specific and generic infrastructure such as roads, ports, harbors, and airports. The provision of well-performing facilities and infrastructures is also crucial to the business performance since these elements also determine the production costs in relation to the reduced costs of transporting raw materials from and the final products to other regions.

- **The harbor and the fishing ports** : this represents the role of ports in facilitating the international trade and industry activity (M. Fujita et al. 1999). The fish processing industries are heavily dependent upon the existence of the harbors and fishing ports due to the fact that they receive raw fish materials as production's inputs from different regions. This is why the presence of these facilities within each region is presumed to be important in determining the spatial location of fishery industries.

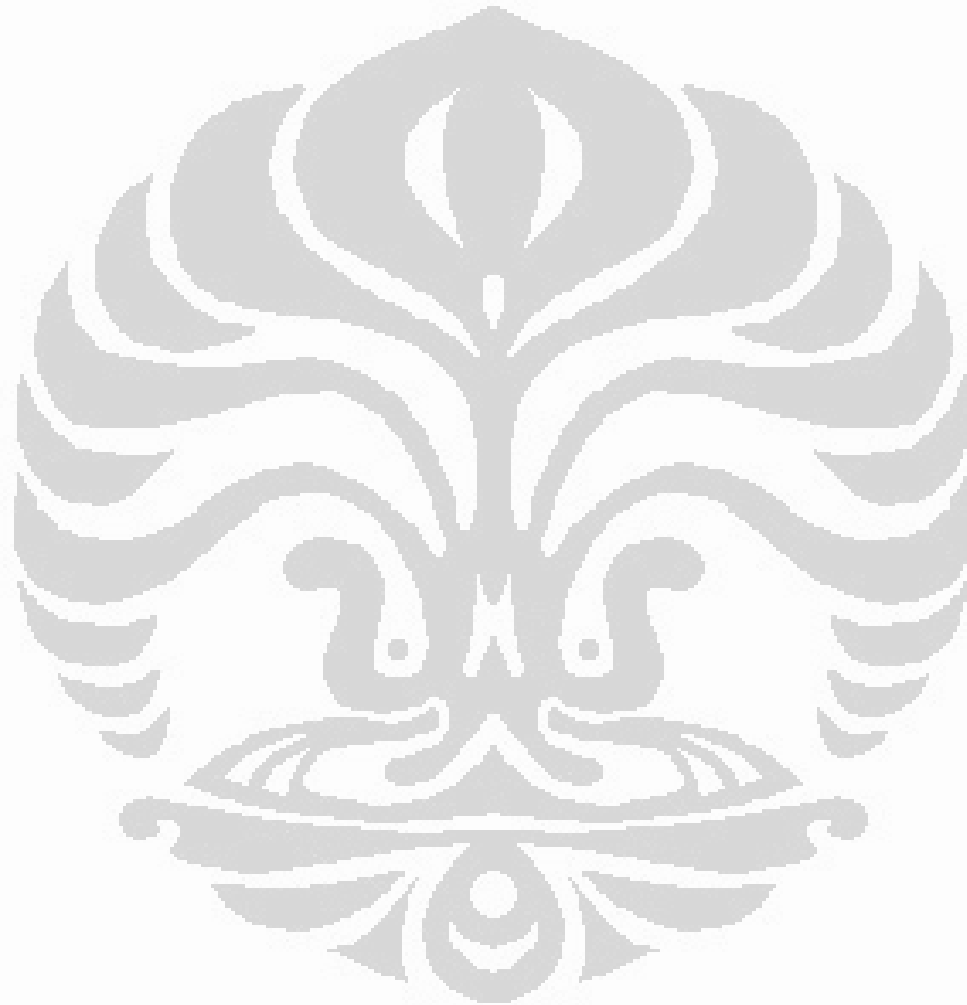

CHAPTER 4 FINDINGS AND ANALYSIS

This chapter discusses about the quantitative and qualitative analyses used in this research. The quantitative analysis examines the major differences between East Java and South Sulawesi in allocating the fish processing industries as well as collecting and exporting fishery products in Indonesia during 2000-2004. In relation to that, the analysis of the inter-regional trading pattern of fishery commodities between East Java and other provinces will be revealed. The quantitative analyses comprise the analysis of Locational Gini Coefficient, and the analysis of panel data model which examines the determinants in affecting the industrial location of fish processing industries.

4.1 Qualitative Analysis

4.1.1 The Major Differences between East Java and South Sulawesi

The Historical Findings

In analysing the major differences between East Java and South Sulawesi, we also have to take into account the historical facts which form their existing regional conditions. Apparently, East Java's rapid development in attracting more industries, especially fish processing industries, has to be reviewed from many perspectives. Not only based on the statistical figures, the presence of many factors have shaped the specific characteristics of each province in relation to the development of marine and fishery sector within each province. The reasons why such a gap exists between these two provinces are the interesting factors that we want to observe in the following sections.

At this point, we see that there is one province, East Java, which is positioned as a leading province in collecting and exporting fishery products to foreign countries as well as allocating most of the fish processing industries in Indonesia. This fact closely links to its achievement as an important economic region in its own right, and as a counterweight to the long-standing economic dominance of Jakarta-West Java for a long time.

As a consequence, East Java has been turned into the Indonesia's second major centre of industrial development after Jakarta/West-Java since 1940, and transformed into a dynamic industrial, commercial and trade hub connecting East Java and eastern part of Indonesia (Dick et al. 1993). It was even recorded that the contribution of East Java's manufacturing industry to a provincial growth rate was higher than for the Indonesian economy as a whole (Santosa and McMichael 2004).

Compared to other provinces, East Java is able to accumulate regional income gains from several factors, which are, the reallocation of resources to more productive, market oriented uses, the acquisition of knowledge and skills, the market widening, and the maintained access to economies of scale. The substantial part of East Java's income growth and the multiplier effects upon production and consumption have been contained within the province rather than leaking away to Jakarta-West Java or overseas (Dick et al. 1993).

Mackie and Zain (1991), and Dick (1993) are among the scholars who have described the success story of East Java since 1960s, with the growth spread across all major sectors in rural as well as urban settings. The growth in East Java has been a cumulative process in most parts of the province, not as the result of investment into one or two leading sectors (Mackie and Zain 1991). In his work, Dick (1993) argued that in the beginning of 1960s, East Java was able to capitalize on geographical diversity, a large population, the benefits of the 'green revolution' and a generally competent bureaucracy to sustain a 'balanced' pattern of growth and development (Dick et al. 1993).

Initially, Located in Brantas delta port in East Java, a storehouse was built to keep the commodities from East Java as well as from other regions and islands. Most of the foodstuffs were carried to Java Island to be bartered for cloves, nutmeg, and mace from the Moluccas; and sandalwood and copper from Timor. Most of these products were also re-exported overseas from the Javanese ports – along with such spices and medicinal grown on the Java Island itself, whereas some other goods imported from the archipelago, particularly metals, were consumed primarily in Java¹².

¹² Ibid.

Since Surabaya, the capital of East Java, becomes the gateway to Eastern Indonesia, the role of markets elsewhere especially coming from outside Java Island are very important. As it has been successfully developing the manufacturing sectors, thus, the products are shipped to Eastern and Western Indonesia, and commercial links are built mainly with resource-rich provinces, namely South and East Kalimantan, and with the poorer islands of Nusa Tenggara which also have a large amount of potential in fishery sector.

Essentially, tracing the position of South Sulawesi in Indonesian trading system has led us to the historical story about this province. According to Sutherland (2004), in the early of 16th century, a Portuguese author, Tome Pires, had recorded that through Makassar Port in South Sulawesi, the food-stuffs, rice, and gold had been traded with textiles from Gujarat, Benggali, and Coromandel. Moreover, in the same time, the vessels of Makassar had been in journeys to Java, Mallaca, Kalimantan, and Siam (Sutherland 2004).

One and half century later, Makassar had become one of the important trading chains of spices, fishery, and forestry commodities from Mollucas and other eastern part of Indonesia. These commodities were bartered with others from western part of Indonesia and from abroad. The consumptive goods, such as foods, tobacco, and horses brought and used internally in Makassar, while its domestic textiles, coins, rice, and iron were exported¹³ (Sutherland 2004).

When Makassar thrive to be one of the important trade centers, the traders and sailors from South Sulawesi were success in building their trading path to and from many producing regions in Indonesia. Tome Pires, in his manuscript, described that initially, these traders were more focusing their trading network to the west as well as sailing to Siam and continuing to Mallaca and Pahang (Malaysia)¹⁴. In the progress, they enlarged the trading network to the east, such as Mollucas, Nusa Tenggara, Java; while zone of Sulu Sea, Macao, and Mallaca became their trading routes in the end of 16th century and the early of 17th century (Poelinggomang 2004).

¹³ Noorduyn, J. (1983). *De Handelsrelatie van het Makassarse Rijk volgens de Notitie van Cornelis Speelman (1669)*. *Nederlandse Historische Bronnen*. S'Gravenhage, Martinus Nijhoff. 3: 97-123

¹⁴ Ibid.

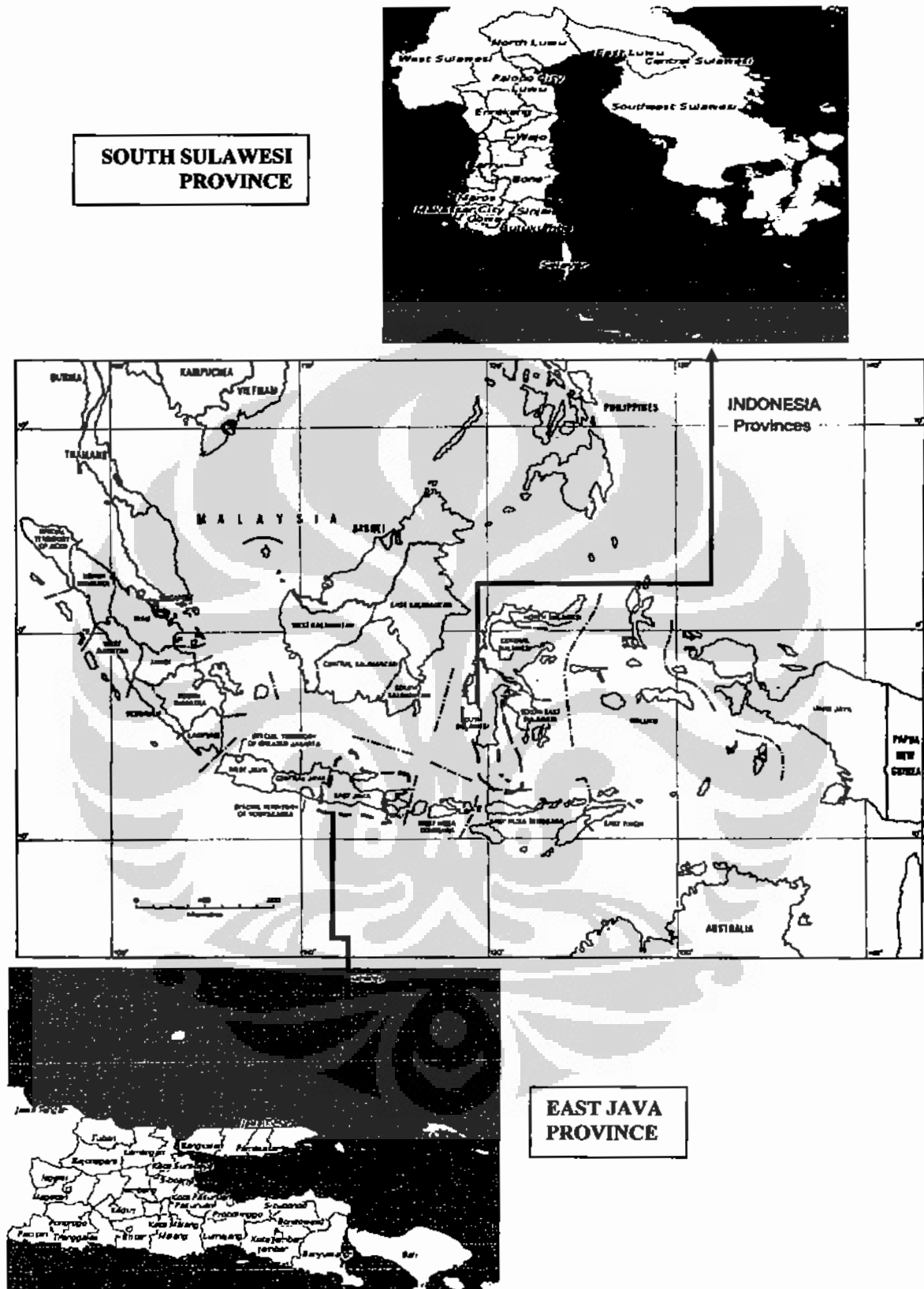

Figure 4.1
Indonesian Map

However, the awakening of the demand of European market for Chinese tea and the demand of Chinese market for fishery commodities in 18th century had influenced the inter-regional trade between South Sulawesi and other regions afterwards. The Dutch East India Trading Company (VOC)¹⁵ opened Makassar Port for Chinese junks, and at the same time stimulating the traders from South Sulawesi to pool the marine and fishery commodities.

These commodities were brought and traded for domestic and international markets, by which the imported commodities from one region were also marketed to other regions or exported abroad¹⁶. However, the commercial trading activities in Makassar were stimulated by the awakening of its economy as a result of the production increase, the expansion of trade, and the development of cash crops in this region¹⁷.

The connection between Makassar and Surabaya was established in 1891 by the Dutch foreign shipping company, named *Koninklijke Paketvaart Maatschappij* (KPM)¹⁸, through re-routing its service via Surabaya and increasing the number of sailings. This action was taken by KPM to expand the routes on which a regular service was operated. From that point, Surabaya became the most important node for channelling imports from the eastern part of Indonesia, and goods for these regions were exported directly from Surabaya, bypassing Makassar (Poelinggomang 1993).

Apparently, the policy to reorient Makassar towards Java was successful in increasing the flow of goods between Makassar and Java, especially after KPM became more active. This fact indicates that the role of South Sulawesi in pooling

¹⁵ In The Netherlands, the Dutch United East India Company (Dutch abbreviation: VOC: *Verenigde Oostindische Compagnie*) was established March 20, 1602. The VOC was mainly a trading company operating extensively throughout the Far East, not only in the Dutch East Indies, now called Indonesia, but also in India, Siam, Ceylon, Persia, Formosa and Japan. The main commodities traded were spices from the Moluccas as well as cotton and silk materials from Indonesia.

¹⁶ Ibid.

¹⁷ Ibid.

¹⁸ KPM was a joint venture with the capital from several Dutch private enterprises with interests in the *Netherlands East Indies* (NEI) founded on September 14, 1888, to replace the former company, the *Nederlandsch-Indie Stoomboot Maatschappij* (NISM) based on the contract to create a more satisfactory network of transportation. As a consequence of weak policy imposed by NISM, the trade in Makassar declined and caused the shifting of foreign and private shipping companies' activity to other small ports other than Makassar and establishing direct relations with Singapore.

and marketing fishery products has been recorded in history since 16th century as the most important region in marine and fishery sector from eastern part of Indonesia.

The Potential in Fishery Sector

As seen in Annex II-a, East Java and South Sulawesi have slightly similar capabilities in producing fishery commodities. Their potencies in producing fish commodities are due to their superiorities in accessing the rich-fishery resources, improving the infrastructures, and establishing the inter-insular shipping system and other types of transportation modes and connections.

South Sulawesi was dominant in processing fish commodities from inland open-water fishery, while East Java was dominant in processing and preserving the commodities from marine fishery (see Annex II-c and II-d). This fact is relevant with the surveys undertaken by the Directorate General of Fisheries throughout Indonesia which identified South and Southeast Sulawesi as the provinces with high potential for development of mariculture, particularly for groupers and sea cucumbers (Ramelan 2002).

The Export

Despite East Java and South Sulawesi were the largest fish producing provinces in 2000-2004, but apparently only East Java did become the largest fish exporting province, whereas South Sulawesi only lied at the 8th rank of the fish exporting provinces (see Annex II-a and II-e). This is because most of the agro-products from South Sulawesi, including fish commodities, are shipped to other regions, particularly Java, for processing and manufacturing.

From the fish commodities export figure of East Java and South Sulawesi in 2003-2004 (see Annex II-g), we see that the volume and the type of primary exported commodities from these provinces were different. The exported commodities from East Java were dominated by alive or non-alive fresh or frozen fishery commodities to Japan and United States, followed by the commodities of fresh, frozen, dried, or salted crustaceans and molluscs, such as shrimp, prawn, crab, and et cetera.

Meanwhile, South Sulawesi mainly exported fresh, frozen, dried, or salted crustaceans and molluscs, followed by other fishery products to Japan, United States, and Singapore. This is due to the fact that the fish commodities coming from eastern part of Indonesia were mostly dominated by crustaceans and molluscs products, thus, there were the chances that these products were directly exported abroad as fresh or preserved products from the production areas without being processed or manufactured in Java Island.

The Investment

East Java's manufacturing capabilities appeared to rely much on high levels of productivity per worker (Dick et al. 1993). The specialty of this province was lying in the its capability in combining a broad industrial base, rising wages and substantial purchasing power, which has given East Java an advantage over other Indonesian provinces. Even, the Surabaya/Malang corridor of East Java has become a booming industrial area that within Indonesia ranks second only to Greater Jakarta--Jabotabek (Dick 1995).

Table 4.1
The Approved Investments (Foreign and Domestic) in Total Sector and Fishery Sector in East Java and South Sulawesi, 2000-2004

Province	Year	Foreign Investment		Domestic Investment	
		Total Sector (Millions US\$)	Fishery Sector (US\$)	Total Sector (Millions US\$)	Fishery Sector (US\$)
East Java	2000	1,113.6	651,000	3,409.16	0
	2001	1,679.0	0	3,043.17	0
	2002	262.5	0	1,797.44	0
	2003	417.7	444,443	1,257.19	0
	2004	325.1	2,000,000	3,801.76	0
South Sulawesi	2000	36.5	0	35,479.69	0
	2001	78.9	0	16,230.09	0
	2002	373.6	0	151.86	0
	2003	43.9	370,000	34,090.94	0
	2004	311.7	0	723.57	0

Source: Bank of Indonesia & Indonesia Investment Coordinating Board, 2005

Universitas Indonesia

As listed in Table 4.1, during 2000-2004, the investments in fishery sector in East Java and South Sulawesi were only coming from foreign investments. This was due to the economic crisis occurred in 1997-1998, which tremendously gave strong impacts to the domestic investors. However, the massive investment, low profit and rate of return from the investment in fishery sector also detained the recovery process of these investors so that they shifted the investments to other more profitable industries, for example: food-stuffs, chemical and pharmacy, metal-good, and other industries.

Particularly, in 2000-2004 East Java was more attractive to foreign investment, while South Sulawesi was more attractive to domestic investments, because most of the investors in East Java, whether invested in fishery sector or others, were the ones who producing commodities for domestic and international markets. This coincides with the fact that fish processing firms were mostly located in East Java, followed by Central Java (see Annex II-1).

Furthermore, the figure in Table 4.2 reveals that the fish commodities largely produced in South Sulawesi were not necessarily processed and marketed within this province. Due to the limited number of fish processing industries and the workers engaged, the fish commodities exported from South Sulawesi were reduced. This implies that there were some important factors affecting these industries to allocate their industries more likely in East Java than in South Sulawesi.

Table 4.2
Number of Fish Processing Industries and Workers Engaged in These Industries
In East Java and South Sulawesi, 2000-2004

Province	Year	Fish Processing Industries (Units)	Employment Working on Fish Processing Industries (Persons)
East Java	2000	201	26,454
	2001	199	24,590
	2002	196	22,681
	2003	167	21,163
	2004	161	22,310

Table 4.2 (Continued)

Province	Year	Fish Processing Industries (Units)	Employment Working on Fish Processing Industries (Persons)
	2001	18	3,984
	2002	20	4,608
	2003	22	4,922
	2004	20	4,453

Source: Directory of Industries, Statistics of Indonesia, elaborated by Author

The Locational Dimension of Manufacturing

Prior to the mid 1970s, the industrial development took place in and around Surabaya and expanded rapidly afterwards assisted by the robust growth in agricultural output and rural income (Dick et al. 1993). Up until 1980s, East Java marketed its product heavily towards domestic demand, both for inner market and for outer islands, especially eastern part of Indonesia, but the foreign markets started to penetrate East Java's market since mid 1980s.

Dick et al (1993) and Dick (2002) contend that while Surabaya was the original manufacturing city in East Java, rapid industrial growth had created a Surabaya–Malang corridor, meanwhile Kuncoro's (2001) analysis of the East Java business sector also locates the main concentration of manufacturing in East Java in what he called *Extended Surabaya*. In particular, the area defined by Dick and Kuncoro similarly captures Surabaya as its core, and includes those regencies possessing superior physical infrastructure; which are the areas surrounding Surabaya (Gresik, Sidoarjo, Malang, Pasuruan, and Mojokerto).

Besides developed in those regions, the manufacturing was even spreading to Nganjuk, following the development of infrastructure and the physical requirements of individual factory sites. In conjunction to its economic growth, East Java has been divided into four main growth corridors (see Figure 2), based on the geographical aspects, economic structures, and economic development level which has been achieved (Utomo 1999):

a. The North-South Corridor

This corridor captures the areas of Gresik – Surabaya – Sidoarjo – Mojokerto – Pasuruan – Malang – Blitar, inhabited by 11.9 million people or 35% of the East Java total population. This area plays an important role in East Java since it has been developed as the leading economic area, dominated by processing industries (35%), trade, hotel, and restaurant (19%). Meanwhile, the output produced by this corridor contributed 55% of East Java's total output in 1999.

b. The South-Western Corridor

The corridor comprises the areas of Jombang – Kediri – Tulungagung – Trenggalek – Nganjuk – Madiun – Ponorogo – Pacitan – Magetan, which was inhabited by approximately 8.1 million people or 24% of the total population of East Java. The economic output produced contributed 21% of East Java's total output, dominated by processing industries (41%), followed by agricultural sector (19%), trade, hotel, and restaurants (19%).

c. The Eastern Corridor

This corridor is formed by the areas of Probolinggo – Situbondo – Bondowoso – Lumajang – Jember – Banyuwangi, which was resided by 7 million inhabitants or 20% of the total population of East Java. Dominated by agricultural sector (33%), trade (20%), and industry (10%), this area contributed 13% to the total output of East Java. Since it still relied on the agricultural sector, the development of this area was strongly backed up by the central government fund instead of its local revenues.

d. The Northern Corridor

The area covers the areas of Ngawi – Bojonegoro – Tuban – Lamongan – Bangkalan – Sampang – Pamekasan – Sumenep, which was inhabited by 7.4 million or 21% of the total population of East Java. The output produced by this area contributed only 11% to East Java's total output. Like the Eastern corridor, the agriculture became the major sector, and it also depended on the central government's fund.

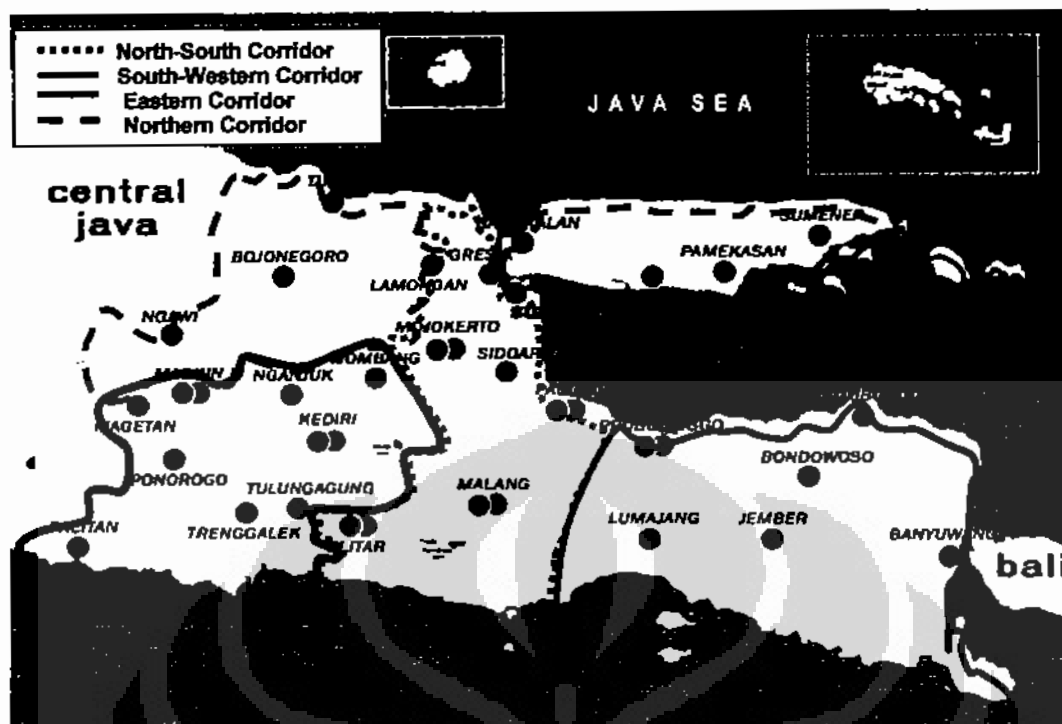

Source: Executive Summary: Strategic Planning and Regional Development Policy of East Java 1999 – 2003

Figure 4.2
The Division of Main Growth Corridors in East Java

The Setting of Industrial Zone

Moreover, the important role of East Java in the trading system has been formed since the 9th century in accordance with the sea trade booming occurred in Java's and Bali's regional economies at that time. The trade boom included not only a growth in the physical and institutional infrastructure of ports, but also an increase in carriage of larger-volume, lower-value cargoes between island in the archipelago (Ray 1999). To a large extent, this inter-island trade and the growth of infrastructures have molded East Java prominently in attracting more investors and establishing their industries.

East Java planners have strongly encouraged domestic and foreign investment to establish their industries within the industrial estates, namely: SIER (Surabaya Industrial Estate Rungkut), Ngoro Industri Persada (NIP) in Mojokerto, PIER (Pasuruan Industrial Estate Rembang) in Pasuruan, Sidoarjo, Probolinggo, and KIM (Kawasan Industri Maspion), located between Surabaya and Gresik, as well as in Sidoarjo and Kediri Regency which also have set up the industrial

Universitas Indonesia

estates. Of the total investments in East Java between 1968 and November 2002, 81 % of domestic investments was mostly allocated in Surabaya, Gresik, Sidoarjo, Mojokerto, Malang, and Pasuruan, whereas 63 % of Foreign Direct Investment was also channelled into those regions.

Compared to East Java, the local government of South Sulawesi established an integrated economic development zone in 1996, named Parepare Integrated Economic Development Zone (IEDZ) to encourage the industrialization development of South Sulawesi. The IEDZ covered some areas from the city of Parepare, as the center of the economic zone, to some regencies, which are Barru, Pinrang, Sidrap, and Enrekang. Moreover, to accommodate the industrial development, the local government has built one industrial estate in South Sulawesi, named Makassar Industrial Zone (KIMA).

Since only one industrial estate was provided in South Sulawesi, then, most of the firms preferred to locate their business in Makassar city, whether inside or close to the industrial estate. The reason was because these companies preferred to the location which has provided the facilities and infrastructures needed by industries, or just taking benefits from the availability of infrastructures, especially to support their production activities.

The Infrastructures

For many years, the prominent role of East Java in allocating the manufacturing industries has been recorded in many researches. One historical element which forms the primary role of East Java is the fact that Java Island as a whole had been constructed as the central of Indonesian government since the colonial area. The setting of the central of the government in Java had given a certain impact to Java Island as a whole and East Java in particular. As a consequence, the commercial and physical infrastructure had been built in Java to encourage more investors coming to this area.

Being used to attract more investments, the transport network of roads and railways extends from the harbor-city of Surabaya through the central core region to distant parts of the province has created a better integrated economic unit than existed in other provinces of Java or in Sumatera or other islands. Anyhow, the

presence of these facilities helps to create relatively cheap, efficient means of moving agricultural commodities from rural areas to the main urban centres where demand is strongest and also of supplying goods from the ports and towns to the villages (Dick et al. 1993)

Even the transport infrastructure is overwhelmingly concentrated in Surabaya, the capacity of East Java's seaports, airports, road networks and power generation all appear to have affected the growth of manufacturing throughout this province. The superiorities of East Java in constructing the infrastructures were portrayed in the presence of the transport infrastructures comprising: the road tollway connecting Tanjung Perak Port to Gresik and Pasuruan; Juanda International Airport near Sidoarjo; a major highway connecting Sidoarjo to Mojokerto and Kertosono; and a highway to Pasuruan.

As East Java's principal maritime gateway and the international container terminal, Tanjung Perak port in Surabaya is one of the main entry ports in Indonesia in distributing goods to the eastern part of Indonesia and within East Java province. Taking advantages over its strategic location and the existence of industrial zones in hinterland areas, such as: Cargo Terminal, Surabaya Industrial Estate Rungkut, and Export Processing Zone at Pasuruan Industrial Estate Rembang, the port is also functioned as the inter-insular shipping center to the eastern part of Indonesia.

Indeed, the availability of the industrial zones and infrastructures altogether located surrounding Tanjung Perak port has formed this province to be more attractive for investors as to support its position as the central production of goods for domestic and international markets. In addition, there are also other local ports, namely Tanjung Wangi (Banyuwangi), Tanjung Tembaga (Probolinggo), and the other four local ports. Based on the information published by Indonesian Shipping Company III (PT. Pelindo III), the frequency of the inter-island shipment at Tanjung Perak port was 15-20% per year, while for the ocean-going shipment was only less than 5% per year. One trigger of the increasing in the domestic shipment was formed by the booming of economic activities in outer islands. Meanwhile, the fact that Surabaya remains Indonesia's second busiest

airport reflects the important role of Juanda airport's as an air hub for Eastern Indonesia.

The different figure appears in South Sulawesi relating to the availability of infrastructures. The road asset infrastructures consists of the toll road, the national road, the provincial road, the regencial road, and the village roads, whereas the Hasanuddin Airport is one international airport which is mainly served as the transit point for the flight to other eastern part of Indonesia.

The sea transportation facilities in South Sulawesi are listed into several categories, which are Makassar port as the major port, and other local ports, namely Pangkajene, Malili, and Parepare. As one of the ports which has the container facilities as existed in Tanjung Perak, Makassar port is developed to support the availability of the industrial facilities located surrounding this port, namely Makassar Industrial Zone, the Export Processing Zone (*Zona Kawasan Berikat*), the City Warehouse and the Cargo Storage.

Since Makassar port is located at Indonesian inland waters, which is more precisely at Makassar Strait, thus, it slightly hampers the development and the expansion of this port. However, despite its weakness, Makassar port has been functioned as the center and international transit hub in the eastern regions, indicated by the higher intensity of unloading and loading activities in Makassar port compared to other ports in eastern part of Indonesia.

The Banking Institutions

Surabaya holds a dominant position in East Java's banking infrastructure, housing the majority of the province's 1,150 domestic, foreign and joint venture banks. In 2004, the total number of offices of banks and finance companies in East Java had reached 2,320 units covering the domestic, foreign, and joint venture banks. However, the banking institutions in South Sulawesi, represented by the number of their offices, were much lower than those in East Java. Of total 488 units of bank offices in 2004, only 2 units were the representatives of foreign banks, while the rest was dominated by state banks, private national banks, and regional government banks, in order.

To large extent, the existence of more financial institutions affects the performance of industries in East Java rather than in South Sulawesi. This is because the banking institutions have played a strong role in assisting the financial services to small, medium, and large scales of industries in the forms of lending for industrial development, and for other variety of services, such as: trade finance, export credit, project finance and investment products.

The Local Policy

More than other provinces, East Java seems to have maintained the professionalism of the former colonial Civil Service, so-called *Binnenlands Bestuur*¹⁹ (Dick et al. 1993). This was a tradition of achievement, especially in the field of development, combined with a high level of personal integrity and commitment. The survival of such values in East Java may be attributed in part to circumstances in the early years of the New Order, when the local government emphasized the three main policy concerns in 1968.

First, the importance of good roads and their rehabilitation were made as the highest priorities. This decision has been thoroughly vindicated by the subsequent revolution in rural-urban transport. Secondly, the grants for the villages (*Inpres Desa*) were spent mainly on roads while the grants for the regencies (*Inpres Kabupaten*) were at first spent mainly on irrigation and communications, but later on health, welfare, and social facilities (Fox 1988 in Dick et al. 1993). Thirdly, the provincial government was careful to avoid undue concentration of public investment in the provincial capital of Surabaya.

In general, the roles of local government are very important in attracting domestic and foreign investors to come. The development of manufacturing industry in East Java has been influenced by the government policy applied specifically in this province. As Dick et al (1993) noted, East Java's success in social and economic policies was in part attributable to a professional bureaucracy and the perceived legitimacy of the provincial administration.

In 1984, the East Java Provincial Agency for Manufacturing introduced a Master Plan for the development of manufacturing industry in the province, in

¹⁹ On the *binnenlands bestuur*, see in H. Sutherland (1979): *The Making of Bureaucratic Élite*, Singapore: Heinemann.

order to establish growth poles for manufacturing. As ruled in the Master Plan, the manufacturing industries are not only concerned to build the industry-specific resources, but also the other development inputs, namely human resources, geographic locations, infrastructures, and other supporting factors.

The distinct government policies were implemented in South Sulawesi to accelerate the local economic growth and develop the industrialization settings in different manner. Despite less attractive to the investors, South Sulawesi has set up different policies and incentives in attracting foreign and domestic investors through provisioning of tax reliefs in the following aspect: 1) The import duty exemption for machines, major equipments, and basic commodities; 2) The exemption of ownership's title transfer tax and income tax; and, 3) The exemption of land and building tax by 50% for eight years.

Of all important policies applied by local government, the provision of strategic industrial zones, infrastructures and transportation systems, considerable investment opportunities, and the capability in revitalizing the government apparatus and system, assisted by a large pool of human resources, are the key elements in forming East Java as the prominent destination for investments, far superior than South Sulawesi.

The Cargo Loading and Unloading Activities

Apparently, the import and cargo unloading activities were dominant in Tanjung Perak port in 2000-2004 (see Table 4.3), due to the fact that most of the large-scale industries in East Java were highly dependent on imported materials for their inputs. Since this port became the transition point for the outer-island regions, then, the goods coming from domestic and international markets were unloaded here and delivered to different areas of destinations afterwards.

During 2000-2004, despite there was an increasing number of exports, imports, unloading, and loading goods in Makassar port, the cargo unloading activity was still dominated here (see Table 4.3). This is because Makassar port has been recorded as the entry gate to deliver products from western part of Indonesia as well as international market to the eastern parts of Indonesia. Particularly, the exports from South Sulawesi are mainly delivered through the

sea-ports, while only few are delivered through the international airport. In 2004, most of the commodities were exported from Malili Port (34.47%), followed by Balantang Port (31.87%), Makassar Port (28.86%), and only a small number of goods were exported through Hasanuddin Airport (1.91%).

Table 4.3
The Operational Activities in Tanjung Perak Port and Makassar Port, 2000 - 2004

No.	Activity	Year (In Tonnes)				
		2000	2001	2002	2003	2004
Tanjung Perak Port						
1	Export	507,232	536,959	568,429	490,141	752,694
2	Import	3,571,711	3,781,040	4,002,637	3,684,249	3,784,135
3	Cargo Unloading	3,273,157	3,464,988	3,668,062	3,620,133	4,852,302
4	Cargo Loading	899,687	952,415	1,008,234	1,111,459	2,047,564
	TOTAL	8,251,787	8,735,403	9,247,362	8,905,982	11,436,695
Makassar Port						
1	Export	861,374	941,242	1,028,516	1,138,219	1,241,077
2	Import	519,913	568,120	620,797	637,017	708,689
3	Cargo Unloading	3,069,953	3,354,604	3,665,649	4,016,075	4,303,801
4	Cargo Loading	1,765,275	1,928,954	2,107,810	2,487,163	2,711,308
	TOTAL	6,216,514	6,792,920	7,422,772	8,278,474	8,964,875

Source: PT. Persero Pelabuhan Indonesia III

Nevertheless, as seen in Figure 4.3 and 4.4, during 2003-2006, the export activities between South Sulawesi and other regions have increased in Makassar more than in Tanjung Perak Port, while the import activities increased in Tanjung Priok Port, and Belawan Port (Bank of Indonesia 2006). This indicates that South Sulawesi has become the transit point in distributing the commodities to western part of Indonesia, such as: Jakarta (Tanjung Priok Port), Surabaya (Tanjung Perak Port), and North Sumatera (Belawan Port).

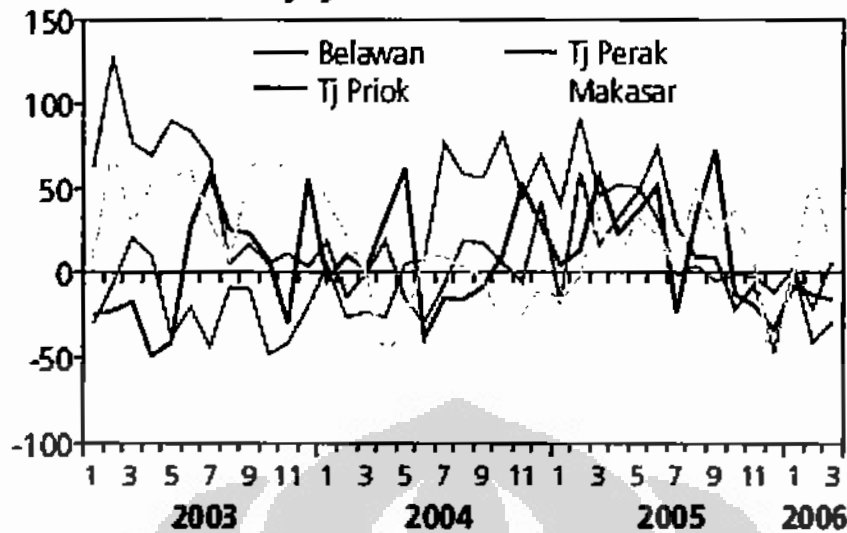

Source: Bank of Indonesia, The Regional Economic Outlook, 2nd Quarter 2006

Figure 4.3
Export Growth Between Provinces (Year on Year Growth)

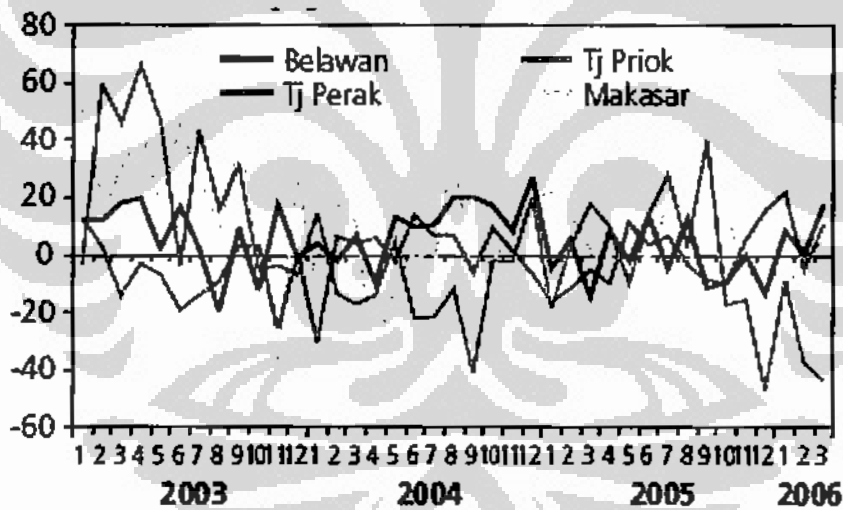

Source: Bank of Indonesia, The Regional Economic Outlook, 2nd Quarter 2006

Figure 4.4
Import Growth Between Provinces (Year on Year Growth)

In overall, the flow of domestic and foreign trading activities between South Sulawesi and other provinces or countries were fluctuating during 2004 until 2006 (see Figure 4.5), especially for foreign export and import activities. It seems that the global economic decline had sufficiently affected the national and regional economies. Despite the flow of foreign export was more fluctuating, it gave the

highest contribution to local revenues, while it was relatively stable for the domestic import. The reason was because the demands of goods from other provinces imported through South Sulawesi have not changed largely adjusted to the economic condition in the regional level.

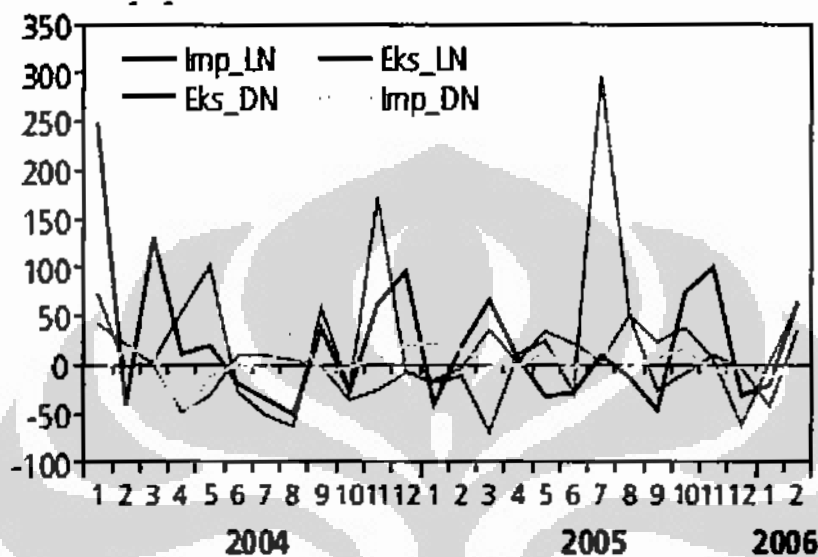

Source: Bank of Indonesia, The Regional Economic Outlook, 2nd Quarter 2006

Figure 4.5
The Loading and Unloading Activities in Makassar Port
(Year on Year Domestic and International Export Import)

The Distribution of Fishery Commodities

In addition, based on the data of the distribution of fish commodities in East Java in 2007 in Figure 4.6, we see that these commodities are mainly coming from outside East Java (90.7%), while the rest (9.3%) is produced within East Java. From the total commodities coming into this province, only 4.7% is exported abroad, meanwhile 95.3% is distributed for domestic market. Apparently, the fish commodities for domestic market are still dominantly used to supply the demands from East Java's market (99.2%), whereas only few is marketed to outside East Java (0.79%).

Despite the production of fishery commodities from East Java is much larger than other provinces (see Annex II-a), it still cannot fully meet the local demands for consumptions as well as for the input needs for fish processing

industries, which are mostly located there. Obviously, taking advantage from its strategic location in the middle of Indonesian archipelago, East Java has been emerging as the main destination for collecting fish commodities from other provinces, and distributing the fish commodities domestically and internationally. Hence, as seen in Figure 4.6, the inter-regional trading activities are formed due to East Java's dependency on the commodities from other provinces in conjunction with its prominent role in supplying the fish processing industries in and exporting fishery products from East Java.

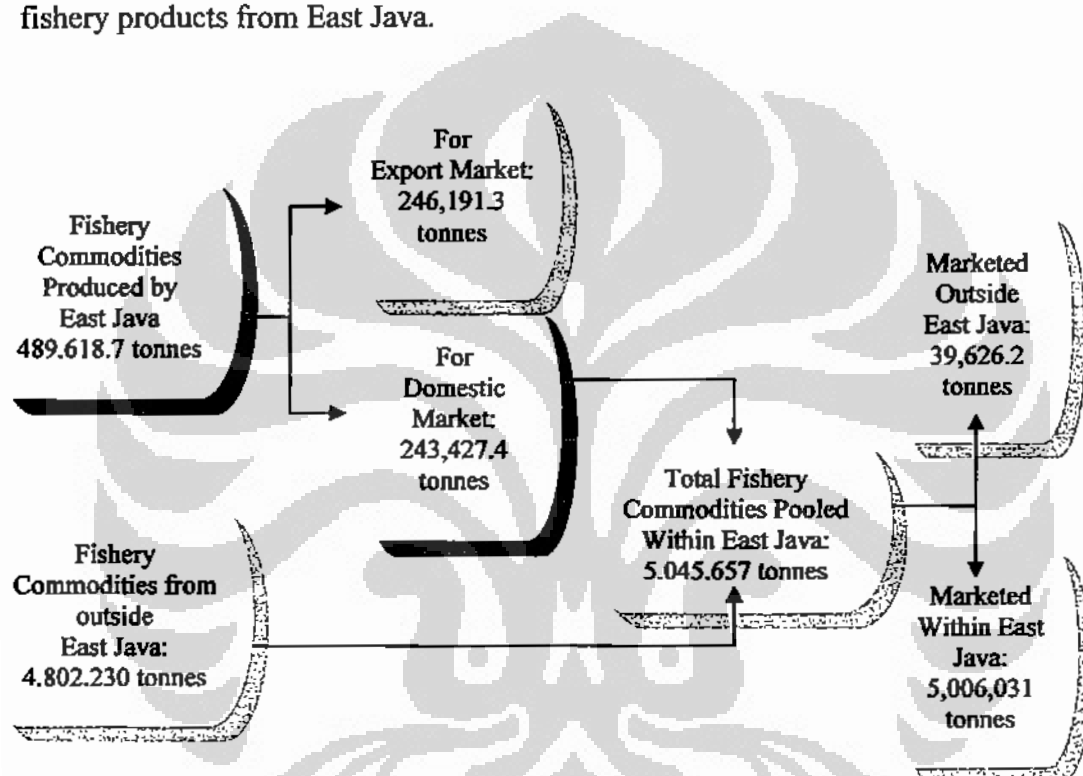

Source: The East Java Provincial Agency for Marine Affairs and Fishery

Figure 4.6
The Supply Chain Activities of Fishery Commodities from East Java

Looking at East Java more deeply, we see that most of the fish processing firms has been located in Lamongan regency, and followed by Sumenep and Trenggalek regencies afterwards (see Annex II-o). Adjusting to the main growth corridors in East Java, these firms were mostly located in the Northern Corridor, and followed by Eastern, North-South, and lastly South-Western Corridor, with the total number of firms were 77, 45, 39, and 25 units, respectively. This coincides with the fact that these firms highly depended on the output from

primary sectors, such as: agriculture and fishery sectors, which predominantly in existed in Northern and Eastern Corridor.

The Investment Constraints

Large enterprises identified poor road maintenance, difficult access to industrial estates, insufficient power supply and an expensive yet insufficient water supply as key infrastructure problems, while small businesses identified the negative impacts of traffic congestion on distribution and the need to supply their own captive power to compensate for the unreliable electricity supply (Jakarta Post - Opinion and Editorial, 1 September 2004). Nevertheless, the group discussions between private sectors from East Java and the World Bank in October 2003 revealed the fact that the infrastructures were still highlighted as a significant business constraint to invest in this province.

In fact, the development of physical infrastructure in East Java did not spread evenly throughout all the province's regencies and municipalities. Particular regions, such as: Surabaya, Gresik and Sidoarjo, experienced faster rates of growth compared to other regions. The gap between these provinces continued and contributed to the regional backwards as the non-industrial regions were suffered from the low local revenues and weak infrastructures.

As also found in South Sulawesi, the perceived hidden cost of investing in East Java may be a factor that has stymied growth in manufacturing. According to Regional Autonomy Watch's 2003 Survey of Regional Investment Attractiveness, three *Kabupaten/Kotamadya* in East Java (Kediri, Malang and Sidoarjo) rank among Indonesia's 20 most attractive sub-provincial locations for investment (8th, 15th and 17th respectively).

One interesting finding from of this survey was the fact that many firms did not regard the additional cost as an obstacle for doing business since those who paid it received benefits in return in terms of local government services and attention (Brodjonegoro 2003). The survey noticed that the illegal levies were parts of the integral features of investing in all the regions. As a result of these 'informal' constraints, sub-provincial governments have had to be inventive in offering incentives to potential investors.

However, the investments in South Sulawesi during 2000-2005 had declined due to limited infrastructures, especially the electricity, and the banking policy which was more favour to the productive sector and the local regulations which hampered the investment in this province. Based on the information released by the South Sulawesi Chamber of Commerce and Industry (Kadin), and the quarterly economic outlook of South Sulawesi published by Bank of Indonesia, 2006, the decreasing amount of investments in South Sulawesi was, somehow, caused by several factors as followed:

1. The lack of up-to-date information about the regional leading sectors
2. The lower number of incentives given by local government
3. The long bureaucracy and the high economic cost in processing business permits which are ruled in the local regulations
4. The limited availability and poor performance of infrastructures, for example: roads, bridges, proper facilities of sea and air transportation.
5. The political and social instability
6. The lack of investments coming into this province

However, the different perspective came from private entrepreneurs about the major constraints which deprived the investments in South Sulawesi. They saw that poor infrastructures, incapable supports from financial sector in terms of the credit allocation to the primary sector which was considered as a risky investment and unofficial tax collection were among the factors which discouraged investors for coming in, especially foreign investors.

The factors mentioned above exist depending on the context in which the local governments have different capabilities in controlling and managing this problem. For example: the lower incentives, high unofficial tax collection, and extra charges, are among those of internal trade barriers which have been generated by new local regulations. This implies that the ability of local executives and legislatures to draft and approve local regulations has become a critical point in shaping the local business climate (Brodjonegoro 2003).

Due to the lack of data availabilities, not all these factors are captured into as the factors affecting the concentration of industries. Despite considering these factors in choosing the industrial location, a few industries tend to locate their

businesses at the industrial zones provided by local governments. However, the other common problems faced by the investors, such as the availability of infrastructures and transportation facilities, and the high economic cost leading to lowered regional outputs, can be used as proxies examined as the factors affecting the industrial location in a panel data model. The summary of main differences between East Java and South Sulawesi which affect the allocation of fish processing industries more in East Java can be seen in Annex II-p.

4.1.2 The Inter-regional Fishery Trading

In general, despite the fish processing industries in Indonesia depend on the raw inputs from local or outer suppliers, it is presumed that there is no integrated fish processing industries within each region. These industries are characterised by the existence of a large number of fishery communities and small producers selling predominantly the fishery commodities to small-scale collectors, and next selling to the exporters, some of whom have direct formal links with processing companies that purchase the dried or semi-processed products (see Figure 4.7).

Mostly, the fishery product exporters are heavily concentrated around Surabaya (East Java) and Denpasar (Bali), with a limited number operating from other centres, such as Makasar, South Sulawesi. However, the fishing activities and the production of fishery commodities are fairly widespread in almost all provinces, and even often located in the more remote areas of West Nusa Tenggara, East Nusa Tenggara, Maluku and Papua. Compared to other fishery resource rich-areas, Java North Sea is the most attractive area visited by fishermen and fleets, followed by Malacca Strait, Maluku, Papua, and South Sulawesi due to an enormous fish stocks in these areas (Nikijuluw 2005).

The fishery commodities are divided into fresh, frozen, and semi-processed commodities. The fresh and frozen commodities are usually tackled for domestic markets or exports, but rarely delivered for inter-island trading because the transportation costs exceed the value added of these commodities. Thus, the commodity that is marketed for inter-island trading is processed and preserved fishery products.

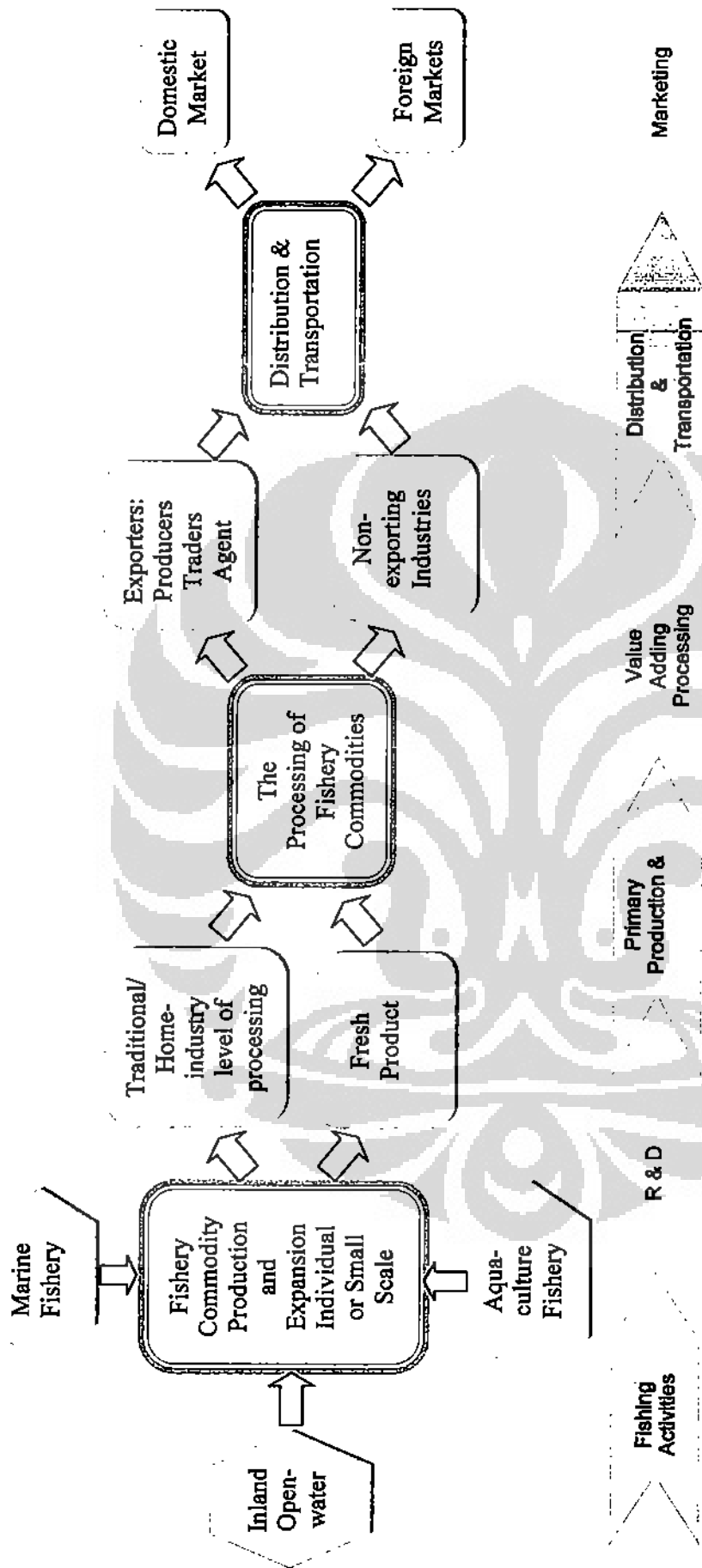

Source: Elaborated based on the data from Directorate General of Fisheries Product Processing & Marketing, Ministry of Marine Affairs & Fisheries

Figure 4.7
The Distribution Chains of Fishery Commodities

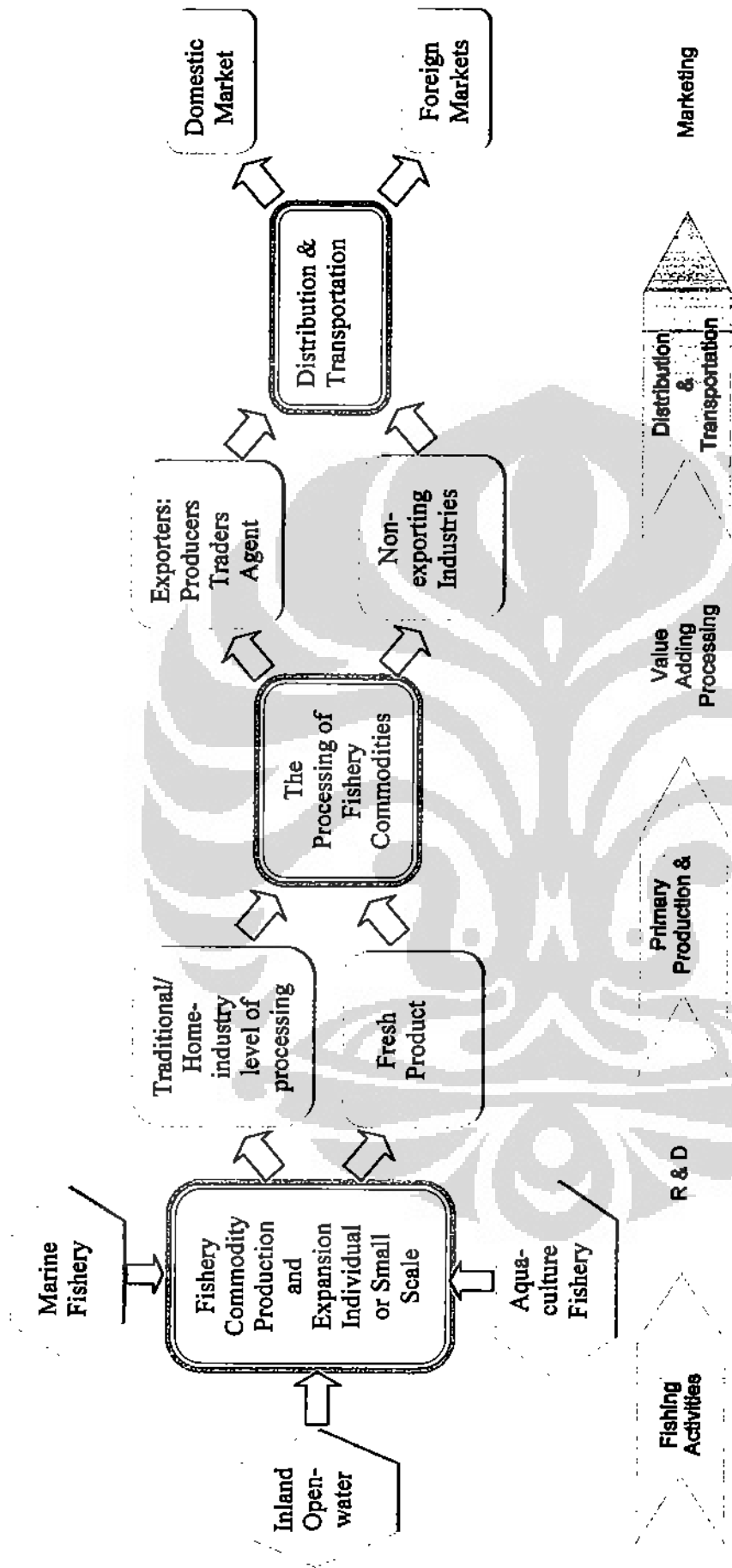

Source: Elaborated based on the data from Directorate General of Fisheries Product Processing & Marketing, Ministry of Marine Affairs & Fisheries

Figure 4.7
The Distribution Chains of Fishery Commodities

In particular, the volume of fish production in every region can be identified as the potential availability of fishery resources within each region. If the volume of inter-regional trading and export-import of fishery commodities are lower than the local production, this implies that the availability or supply of fishery stocks is very high in the local level²⁰.

As seen in Figure 4.8, the fishery commodities from different islands are usually delivered to East Java to be processed by fish processing industries in this province or exported directly to abroad or delivered to South Sulawesi for domestic consumptions or to be exported. Although some manufacturing and processing were done in Makassar, most of its agro-products and raw materials are shipped to other areas of Indonesia, particularly Java, for processing and manufacturing, before delivered to domestic and international markets (The Municipal Government of Makassar and the World Bank 2003).

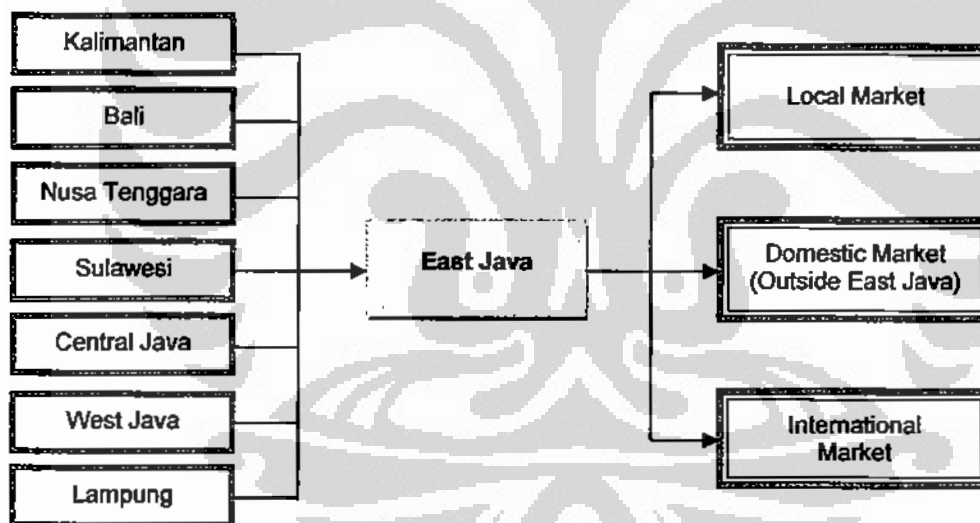

Source: Elaborated based on data from The East Java Provincial Agency for Marine Affairs and Fishery, 2007

Figure 4.8
The Trading Chains of Fishery Commodities in East Java

One example of the fish commodities traded is seacucumber (*holothurian species*). This commodity is exported to Hongkong, Singapore, Taiwan, Japan, by distributors from East Java who buy directly from the fish farmers in East and

²⁰ Ibid.

West Nusa Tenggara, South Sulawesi, Southeast Sulawesi, Maluku, and Papua, who have been cultivating this commodity regularly.

4.2 Quantitative Analysis

4.2.1 The Concentration Measure

The degree of concentration of fish processing industries is measured using the Locational Gini Coefficient (LGC) for the national and East Java level in particular. For each level, we calculate the coefficient based on two types of data since we would like to compare the trend of geographical distribution of employment working on fish processing industries and on all sectors for both across provinces as well as across regencies in East Java. Firstly, LGC is based on the data of employment working on the fish processing firms. Secondly, it is based on the data of employment working on all sectors.

From the Table 4.4, we see that the Gini Coefficients for employment in fish processing industries were relatively stable from 2000 until 2004, especially for the last three years, and slightly increased from 0.925 in 2000 to 0.935 in 2004. Using the employment data as a proxy to measure the distribution of fish processing industries, these values imply that the distribution of fish processing industries were extremely unequal across provinces, meaning that these industries were concentrated in a certain location or province.

Table 4.4
The Locational Gini Coefficient at National and East Java Level, 2000-2004

Year	The Locational Gini Coefficient	
	Based on Employment on Fish Processing Industry	Based on Total Employment
National Level		
2000	0.925	0.550
2001	0.937	0.586
2002	0.935	0.584
2003	0.935	0.578
2004	0.935	0.600

Table 4.4 (Continued)

Year	The Locational Gini Coefficient	
	Based on Employment on Fish Processing Industry	Based on Total Employment
East Java Level		
2000	0.564	0.206
2001	0.542	0.210
2002	0.592	0.225
2003	0.580	0.227
2004	0.570	0.216

Source: Author's analysis, 2008

This result corresponds to the previous finding which reveals that almost 36 % of the fish processing firms were concentrated in East Java, which was greater than the national average of firm concentration, which only reached 4 %. The similar figure appears on the distribution of employment working on these industries, in which almost 29 % of this category was located in East Java, also exceeding the value of the national average, which was around 4 %. The values of Gini coefficient for the total employment were also slightly increasing from 0.55 in 2000 to 0.60 in 2004, implying that the distributions of employment were moderately unequal across province following the distribution of population in each province.

In addition, the unequal distribution of fish processing industries is also affected by specific characteristics of these industries, particularly among the ones which are located in different regions or even island. The regional concentration of fish processing industries in a particular province is made up by the integration of both upstream and downstream value chain activities across-sectors. In fact, these industries are just a minor representation of industrial complexes which are usually dominated by other thriving industries as such, for example: manufacturing industries.

Particularly, based on the Gini Coefficients for East Java level in Table 4, it shows that the distribution of employment working on fish processing industries was moderately unequal across regencies in East Java. The value of this coefficient was slightly increasing from 0.56 in 2000 up until 0.59 in 2002, and

Universitas Indonesia

then decreasing into 0.57 in 2004. This implies that although these industries were not equally distributed across regencies, but, compared to the national level, the distribution of the employment was relatively 'equal' across regencies, or not highly concentrated in a certain location or regency.

The different figure appears in the Gini Coefficient for employment working on all sectors. The values show that the distribution of total employment was highly equal across regencies, following the distribution of population and working fields which were distributed relatively equal across regencies. Seemingly, the development progress which was rapidly taking place since the industrialization booming in 1980s onwards has affected the economic growth and the development of infrastructures throughout East Java.

Up to a certain level, the cumulative growth process taking place in this province since 1960s had spread across all major sectors in rural and urban settings giving the impact to the creation of new working opportunities for the skilled and unskilled labours to enter the labour market. Altogether with the other characteristics which form these industries as a whole, we can conclude that the unequal distribution of fish processing industry exists because of the following conditions:

1. There is no a geographic concentration of interconnected fish processing industries which operate and compete as an interdependent system within every province since most regions are developing the marine and fishery resources independently. Thus, the concentration of fishery industries are restrained from the integrated framework capturing the whole process started from fishing activities to the final distribution.
2. Infrastructural deficits, inability to access capital, regional isolation, and the absence of a skilled workforce altogether act as barriers to the creation of clusters in the fisheries industries.
3. The knowledge spillovers do not happen commonly and frequently among the fishermen or fish farmers, so that the knowledge about technologies, skills, and the production techniques does not spread over widely.
4. There is no significant related industry resides within this location to support the fishery industry. For example: the marine engineering industry which

plays a vital support role, with its building, repair and maintenance of the fishing fleet, and other related industry complementors, such as equipment suppliers to support both the aquaculture and fishing sectors, and consumer goods and distribution networks.

4.2.2 Panel Data Model

In order to check the relationship and the significance of determinants which affect the industrial concentration, we use the econometrical study by constructing a panel data model. Based on this model we do the regression of fixed effect and random effect using the share of employment in fish processing industries in each province to the national employment in all sectors, as the dependent variable. Hence, the result can be seen in Table 4.5.

Based on the regression result and the Hausman test, we find that the random effect model is more appropriate in our case with the value of R-squared 34.29%, and this model is free from the problems of heteroscedasticity, autocorrelation, and multicollinearity. The statistical result shows that there are three variables which are significant. Two variables which are significant at 90% confidence interval are 'sgdpf' and 'empdens', while one variable, 'fishport', is significant at 95% confidence interval, with the coefficients at -0.00044, 2.97e-08, and 6.49e-07, respectively.

Table 4.5
The Panel Data Result

	Coef.	Std. Err.	z	P> z
sgdpf	-0.0004473	.0002391	-1.87	0.061
empdens	2.97e-08	2.98e-09	9.95	0.000
prod	-7.19e-12	2.95e-11	-0.24	0.808
presvprod	1.83e-11	4.04e-11	0.45	0.651
infrarea	2.48e-06	3.15e-06	0.79	0.431
harbor	-1.50e-13	1.43e-13	-1.05	0.293
fishport	6.49e-07	3.58e-07	1.82	0.070
_cons	.0000289	.0000191	1.51	0.131

Source: Author's analysis

Unlike other significant variables, a one unit increase in the share of GRDP by fishery sector will reduce the share of employment working on the fish processing industries to the national employment by 0.00044 point, holding other variables constant. The reason is because the increase in outputs produced by fish processing industries gives multiple sequences to these industries. By producing more fishery products, the firm is experiencing the increase in its economic of scales, and it alters to the new sequence of production method from a labor intensive to a capital intensive method, in which the roles of human skills are replaced by machineries²¹.

Furthermore, a one unit increase in the average employment intensity will increase the share of employment working on fish processing industries to the national employment by 2.97e-08 point, holding other variables constant. The result is very obvious since this variable is used to examine the impact of the labor market to the concentration of fish processing industries. Based on the result, we can prove that the labor market pooling, specifically for the labors working on fish processing industries, is an important variable which affect the industrial concentration and has a positive impact to the fish processing industries to be relatively more concentrated, as matched with the researched conducted by Rosenthal and Strange.

From the coefficient of fishport variable, we find that one unit increase in the number of fishing port will increase the share of employment working on fish processing industries by 6.49e-07 point, holding other variables constant. The reason is because the existence of fishing ports gives a positive impact to the fish processing industries regarding to the fact these ports have an important role in collecting and distributing the fish raw materials as well as the final products from fishing and capture activities to the market.

However, based on the result, we find that there are four variables which are insignificant: namely '**prod**', '**presvprod**', '**infraea**', and '**harbor**'. This result

²¹ This argument can be proven using the capital used by fish processing industries. By dividing the amount of capital used by the output produced, and compared it with the average intensity of labour used, we can observe whether the fish processing industry can be categorized as a capital-intensive or labour-intensive industry. But, since we do not have the data of capital used by the fish processing firms across provinces in Indonesia, thus, we cannot examine this argument using the quantitative approach.

proves that the availability of resource endowments does not necessarily represent the concentration of fish processing industries, since the fish commodities needed to supply these industries in a particular province are mostly coming from other regions, just like in the case of supplying the fish commodities from other regions to the industries in East Java.

The insignificant variable of 'infraarea' and 'harbor' implies that the existence of fish processing industries in certain provinces was triggered by other crucial factors instead of these two factors. Seemingly, the allocation of fish processing industries in a specific location was not merely caused by the existence of well-performing local infrastructures, but also affected by other important factors which are not captured in the model.

4.2.3 Summary of Analyses

Despite, theoretically, these factors are considered very important in accommodating the concentration of the industries; it seems that the historical aspects and benevolent local policies are highly conducive in developing fish processing industries in Indonesia. This condition exists due to the specific characteristics of East Java and South Sulawesi in relation to the development and allocation of fish processing industries which are highly affected by the economic aspects as well as the social and historical aspects.

Having had a cumulative growth process in most part of this province since 1960, and complemented by the booming of industrialization from early 1980s onwards, East Java has been able to form an improved economic development as well as one of the most important industrial bottom lines in Indonesia, which were based on the superiorities in its geographical diversity, a large population, and a generally competent bureaucracy to sustain a 'balanced' pattern of growth and development.

However, the other factors which are not captured in the model and also determine the prominent role of East Java in allocating the fish processing industries compared to other provinces are the existence of industrial zones, transportation facilities, variety of financial institutions, and the increasing demand of fishery commodities from domestic markets. These are among the factors which also particularly have encouraged the establishment of fish

processing industries in East Java, and increased the number of intermediate and final fishery commodities produced and exported from East Java to domestic and international markets.

Being developed as the most important node in the inter-regional trade since 9th century as well as the export and import channel from eastern part of Indonesia since 18th century, this initial development had triggered the establishment of much of the resource basis and infrastructure in East Java in colonial times. In the progress, stimulated by the Green Revolution in rice production in the 1960s and the growth of the manufacturing industry in the late 1980s, East Java has achieved its economic growth and development more widely throughout the whole province. More general, the expansions of the construction and transport sectors as well as the commercial and financial activities have been complementary to this achievement and have provided vastly more employment (Dick et al. 1993).

As occurred in adjacent periods, the success of East Java's development lied in the way various developments in the province have reinforced each other since 1970: namely economic, administrative, and political changes, different sectors of the economy, and internal and external stimuli. Most of the internal stimuli came from the internal generation of higher incomes within the province, hence increasing the local demand for goods and services. Meanwhile, the external stimuli captured the big increases in government spending, the capital inflows in the form of Jakarta-based and foreign investment, the expansion of bank credits, new imported technologies, and the general increase in purchasing power and commercial demand throughout Indonesia during the oil boom years in 1974-1983²².

²² Ibid.

CHAPTER 5 CONCLUSION

The industries choose to allocate their businesses in particular locations, based on their preferences and characteristics, which are optimum to increase the productivity and enhance the economic outputs. Having researched on the fish processing industries, we see that most of these industries are located in East Java during 2000-2004. Apparently, the role of East Java was also prominent in collecting and exporting fishery products compared to other provinces.

Focusing more on the major differences between East Java and South Sulawesi, this paper investigates the prominent role of East Java in allocating the fish processing industries and exporting fishery products compared to South Sulawesi, and analysing the factors which affect the industrial location of fish processing industries in Indonesia. Although the potency of marine and fishery sector exists almost in every province, it seems that there is a red thread connecting East Java with other provinces in collecting and distributing the marine and fishery commodities.

Based on the preliminary studies about East Java and South Sulawesi, on one hand, the historical factor of locating central government in Java from the colonial era had an important impact on the island's history as it permitted the licensing regulations as well as commercial and physical infrastructure to be far superior in Java, thus, the firms has been encouraged to locate there (Kuncoro 2002). Moreover, the prominent role of East Java is mostly formed by the booming of industrialization in East Java from early 1980s onwards, assisted by the local policies performed as incentives for the investors to establish their business here. On the other hand, Makassar, a capital of South Sulawesi province, had been a major trading centre, an entrepôt linking eastern and western Indonesia in the early 17th century.

To a certain level, the performance of well-improving infrastructures in East Java determines the productivity level of fish processing industries and affects the investors' preferences to set up their business more likely in East Java compared to South Sulawesi. In fact, the existence of industrial zones, transportation

facilities, financial institutions, as well as conducive local government's policies are also among the factors which have encouraged the establishment of fish processing industries and the increase in fishery commodities produced and exported in East Java.

Although some manufacturing and processing activities are held in Makassar, most of their agro-products and raw materials are shipped to other areas of Indonesia, particularly Java, for further processed and manufactured activities into the intermediate or final products. Therefore, the fishery commodities from regions in the eastern part of Indonesia are most likely delivered to East Java as the inputs for the fish processing industries in this province before delivered to domestic markets or exported abroad.

Based on the result of Locational Gini Coefficient, we see that the distribution of fish processing industries were extremely unequal across province during 2000-2004, implying that these industries were concentrated in certain provinces. The different result appears for the total employment, which shows that the distribution of employment was moderately unequal across province following the distribution of population in each province. In East Java level, despite these industries were not equally distributed across regencies, but, compared to the national level, the distribution was relatively 'equal', meaning that the employment working on these industries was not concentrated in a certain location or regency. Somehow, these findings coincide with the characteristic of fish processing industries in Indonesia.

Representing the minor concentration of industries compared to other leading industries, thus, they perform independently across province, but benefitting from the integration of both upstream and downstream value chain activities across-sectors. Eventually, each region may accept raw fish products or preserved ones from others as inputs to produce the fishery products, but apparently this is conducted by small-scale owner-operated fish farms apart from an integrated scale of industries.

Based on the result of random effect model, we find that the share of output from fishery sector, the average intensity of employment working on fish processing industries, and the availability of fishing ports are the significant

determinants in affecting the industrial location of fish processing industries across province, represented by the share of employment working on these industries to the total national employment.

This result proves that the availability of resource endowments does not necessarily represent the concentration of industries since there has been an inter-regional linkage between provinces in supplying the commodities for fish processing industries. Apparently, the existence of fish processing industries in certain provinces was triggered by other crucial factors which are not captured in the model, such as the historical aspects and benevolent local policies which are highly conducive in developing fish processing industries in Indonesia.

Taking benefits from the historical background and its position as the gateway connecting the trade between western part and eastern part of Indonesia, East Java had improved its economic development to become one of the most important industrial bottom lines in Indonesia. Finally, the existence of industrial zones, transportation facilities, variety of financial institutions, and the increasing demand of fishery commodities from domestic markets have also encouraged the establishment of fish processing industries in East Java, and increased the number of fishery commodities produced and exported from East Java to domestic and international markets.

Finally, the establishment of the facilities and infrastructures in colonial times was initially triggered by East Java's involvement in the inter-regional trade since 9th century as well as in the export channel from eastern part of Indonesia since 18th century. However, the continuity of East Java's development and its advancement in the industrialization was not a matter of having to create entirely new industries when the government funds were excessively available during the oil boom in 1974-1983, but it is mostly influenced by the rehabilitation and expansion of existing facilities by local government as well as the implementation of benevolent policies.

REFERENCES

- Audretsch, D. and M. Feldman (1996) 'R & D Spillovers and the Geography of Innovation and Production', *American Economic Review* 84(5): 630-640.
- Bank of Indonesia (2006) 'Tinjauan Ekonomi Regional Triwulan II 2006'. Jakarta: Bureau of Monetary Policy, Directorate of Economic Research and Monetary Policy.
- Bieri, D. (2006) 'Picking a Winner? Evidence from the Non-Manufacturing High-Tech Industry in the Blacksburg MSA'. Munich: Munich Personal RePEc Archive.
- Brodjonegoro, B. (2003) 'The Effects of Decentralisation on Business in Indonesia'. Paper presented at the conference 'Indonesia Update Conference, 26-27 September 2003, Australian National University', Canberra. Available online.
- Brown, M. (1994) 'Using Gini-style Indices to evaluate The Spatial Patterns of Health Practitioners: Theoretical Considerations and An Application Based on Alberta data', *Soc. Sci. Med* 38(9): 1243-1256.
- Damgaard, C. and J. Weiner (2000) 'Describing Inequality In Plant Size or Fecundity', *Ecology* 81(4): 1139-1142.
- David, P. and J. Rosembloom (1990) 'Marshallian Factor Market Externalities and The Dynamics of Industrial Localization', *Journal of Urban Economics* 28: 349-370.
- Davis, D.R. and D.E. Weinstein (2002) 'Bones, Bombs and Break points: The Geography of Economic Activity', *American Economic Review* 92(5): 1269-1289.
- Dick, H. (1995) 'The Transformation of Comparative Advantage: East Java 1920 - 1990s', *Bulletin of Indonesian Economic Studies* 31(1): 41-72.
- Dick, H., J.J. Fox and J. Mackie (1993) *Balanced Development: East Java in the New Order*. Singapore: Oxford University Press.
- Dumais, G., G. Ellison and E.L. Glaeser (2002) 'Geographic Concentration as a Dynamic Process', *The Review of Economics and Statistics* 84(2): 193-204.

- Ellison, G. and E.L. Glaeser (1997) 'Geographic Concentration in U.S. Manufacturing Industries: A Dartboard Approach', *The Journal of Political Economy* 105(5): 889-927.
- Falcıoğlu, P. and S. Akgüngör (1999) 'Regional Specialization and Industrial Concentration Patterns in Turkish Manufacturing Industry After Trade Liberalization'. Istanbul: Faculty of Business, Dokuz Eylül University.
- Fedderke, J. and G. Szalontai (2005) 'Industry Concentration in South African Manufacturing: Trends and Consequences, 1972-1996' (Working Paper): World Bank Africa Region.
- Fujita, M., P. Krugman and A.J. Venables (1999) *The Spatial Economy: Cities, Regions and International Trade*: MIT Press.
- Fujita, M. and T. Mori (1996) 'The Role of Ports in the Making of Major Cities: Self-Agglomeration and Hub-Effect', *Journal of Development Economics* 49(93-120).
- Fujita, M. and J.F. Thisse (1996) 'Economics of Agglomeration', *Journal of the Japanese and International Economies* 10: 339-378.
- Head, K., J. Ries and D. Swenson (1995) 'Agglomeration Benefits and Location Choice: Evidence from Japanese Investment in the United States', *Journal of International Economics* 38: 223-247.
- Holmes, T.J. and J.J. Stevens (2002) 'Geographic Concentration and Establishment Scale', *Review of Economics and Statistics* 84(4): 682-691.
- Holmes, T.J. and J.J. Stevens (2004) 'Spatial Distribution of Economic Activities in North America', in *Handbook of Regional and Urban Economics* (Vol. 4): J. V. Henderson and J-F. Thisse, eds. Amsterdam: North Holland.
- Hong, J. and S. Fu (2008) 'Information and Communication Technologies and Geographic Concentration of Manufacturing Industries: Evidence from China'. Beijing: Social Science Research Network.
- Kathuria, V. and A.S. George (2005) *Spatial Location of Industries – Factors Influencing Locational Choice*. Paper presented at the conference '2nd Annual Conference on Economic Growth and Development'.
- Krugman, P. (1991a) *Geography and Trade*. Cambridge, Massachusetts: MIT Press.

- Krugman, P. (1991b) 'Increasing Returns and Economic Geographic', *The Journal of Political Economy* 99(3): 483-499.
- Kuncoro, A. (2002) 'The New Laws of Decentralization and Corruption in Indonesia: Examination of Provincial and District Data'. Jakarta: Indonesian Regional Science Association.
- Lafourcade, M. and G. Mion (2004) 'Concentration, Agglomeration and the Size of Plants: Disentangling the Sources of Co-location externalities', *Journal of Economic Literature*(42).
- Lovely, M.E., S. Rosenthal and S. Sharma (2002) 'Information, Exporting, and the Agglomeration of U.S. Manufacturing Headquarters'. New York: Department of Economics, Syracuse University.
- Mackie, J. and J. Zain (1991) *Balanced Growth and Diversification, in Hill Unity and Diversity*. Singapore: Oxford University Press.
- Marshall, A. (1920) *Principles of Economics* (Vol. 8th Edition). London: Cambridge.
- Martin, P. and C.A. Rogers (1995) 'Industrial Location and Public Infrastructure', *Journal of International Economics* 39: 335-351.
- McCann, P. (2001) *Urban and Regional Economics*. New York: Oxford University Press.
- Nachrowi, N.D. and H. Usman (2006) *Pendekatan Populer dan Praktis Ekonometrika Untuk Analisis Ekonomi dan Keuangan*. Jakarta: Economic Faculty, University of Indonesia.
- Neary, J.P. (2001) 'Of Hype and Hyperbolas: Introducing the New Economic Geography', *Journal of Economic Literature* 39: 536-561.
- Nikijuluw, V.P.H. (2005) *Politik Ekonomi Perikanan: Bagaimana dan Kemana Bisnis Perikanan?* Jakarta: PT. FERACO.
- Nyström, K. (2005) 'Determinants of Regional Entry and Exit in Industrial Sectors'. Stockholm: The Royal Institute of technology, Centre of Excellence for Science and Innovation Studies.
- Poelinggomang, E.L. (1993) 'The Dutch Trade Policy and its Impact on Makassar's Trade'. in T. Day et al. (eds). *Review of Indonesian and*

- Malaysian Affairs* (Vol. 27). Sydney: The Department of Southeast Asian Studies, School of Asian Studies
- Poelinggomang, E.L. (2004) 'Perdagangan Maritim Masyarakat Sulawesi Selatan', in D. Pradadimara et al. (eds), *Kontinuitas dan Perubahan dalam Sejarah Sulawesi Selatan*. Yogyakarta: Penerbit Ombak.
- Porter, M.E. (1990) *The Competitive Advantage of Nations*. New York: Free Press.
- Ramelan, S.H. (2002) *Present Status and Strategy of Indonesian Mariculture Development* Paper presented at the conference 'APEC/NACA Cooperative Grouper Aquaculture Workshop'.
- Ray, H.P. (ed.) (1999) *Archaeology of Seafaring: The Indian Ocean in the Ancient Period*. New Delhi: Pragati Publications.
- Resende, M. and R. Wyllie (2001) 'Industrial Location and Local Incentive Policies in Brazil: an Empirical Investigation'. Rio de Janeiro: Universidade Federal Rio de Janeiro, Instituto de Economia.
- Rosenthal, S.S. and W.C. Strange (2001) 'The Determinants of Agglomeration', *Journal of Urban Economics* 50: 191-229.
- Rosenthal, S.S. and W.C. Strange (2002) 'Evidence on the Nature and Sources of Agglomeration Economies', in *Handbook of Urban And Regional Economics* (Vol. 4). New York: Department of Economics, Syracuse University.
- Sadras, V. and R. Bongiovanni (2004) 'Use of Lorenz Curves and Gini Coefficients to Assess Yield Inequality Within Paddocks', *Field Crops Research* 90: 303-310.
- Santosa, B.-H. and H. McMichael (2004) 'Industrial Development in East Java: A Special Case?' Melbourne: Australian National University.
- Sutherland, H. (2004) 'Kontinuitas dan Perubahan Dalam Sejarah Makassar: Perdagangan dan Kota di Abad ke-18', in D. Pradadimara et al. (eds), *Kontinuitas dan Perubahan dalam Sejarah Sulawesi Selatan*. Yogyakarta: Ombak.
- The Municipal Government of Makassar and The World Bank (2003) 'Summary of Results Interviews with Local Businesses in Makassar'. Paper presented

at the conference 'Makassar Regional Private Sector Forum', Makassar, South Sulawesi. Available online.

Tveteras, R. (2001) 'Effects of Regional Agglomeration of Salmon Aquaculture on Production Costs': Centre for Fisheries Economics.

Utomo, H.I. (1999) *Executive Summary: Strategic Planning and Regional Development Policy of East Java 1999 - 2003*. Retrieved from.

Vickerman, R.W. (ed.) (1991) *Infrastructure and Regional Development*. London: Pion.

Weiner, J. and O.T. Solbrig (1984) 'The Meaning and Measurement of Size Hierarchies in Plant Populations', *Oecologia* 61: 334-336.

Wooldridge, J.M. (2002) *Introductory Econometrics: A Modern Approach* (Vol. 2nd Edition): Thomson/South Western.

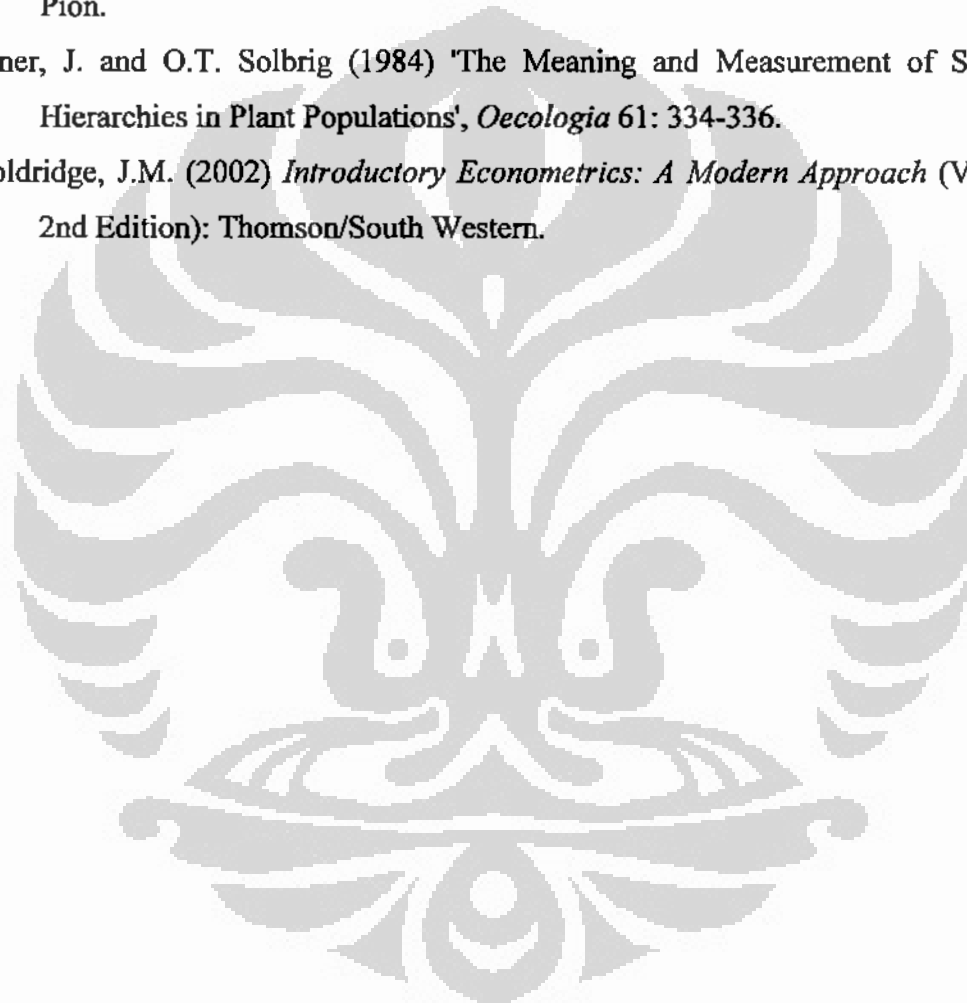

ANNEX I

Hirschman-Herfindahl Index (HHI)

HHI is used to address the geographic dispersion and uneven distribution of employment within subregions of an area under study. This index is defined as followed:

$$HHI_i = \sum_{i=1}^n (s_i^2)$$

Where:

s_i is industry i 's at the level of the subregion compared to the region; and n is the number of counties within the region. The index is equal to 1 if there is absolute concentration and it takes a value of $1/n$ if employment in the industry is equally dispersed across the region.

The Location Quotient (LQ)

The location quotient (LQ) is the standard measure of employment distribution that controls for the size of the region. The relative concentration of industry i in region j is defined as

$$LQ_i = \frac{(E_{ij}/E_{in})}{(E_j/E_n)}$$

Where:

E_{ij} is employment in industry i in region j ;

E_j is total employment in region j ;

E_{in} is national employment in industry i ; and

E_n is total national employment.

Thus, a LQ of greater than one indicates that there is an above average proportion of employment in a given industry in a given region. Industries with an LQ above 1.25 are generally viewed as constituting the export-oriented economic base.

Plotting The Locational Gini Coefficient Area

Before constructing the LGC area, first we need to plot the Lorenz curve²³. Thus, the Gini coefficient (or Gini ratio) is defined graphically below as a ratio of two areas, namely the area between the line of perfect equality and the Lorenz curve (A) divided by the area representing the difference between the perfect equality and perfect inequality lines (A+B), lying below or above the line of equality.

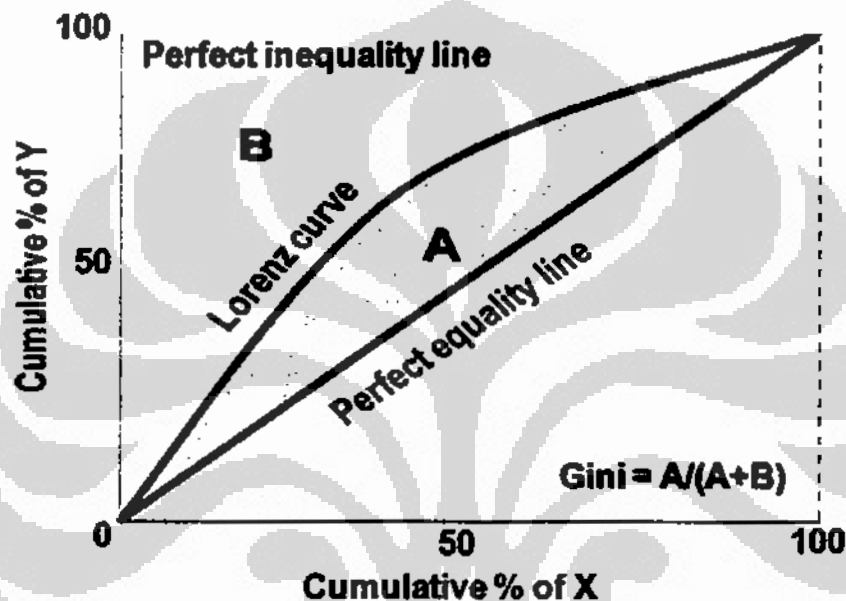

Source: 1998-2008, Dr. Jean-Paul Rodrigue, Dept. of Economics & Geography, Hofstra University.

Annex I-a
The Area of Gini Coefficient

The Problem of Multicollinearity

²³ The Lorenz curve is a graphical representation of the proportionality of a distribution (the cumulative percentage of the values). To build the Lorenz curve, all the elements of a distribution (individuals or plants) must be ranked by size or ordered from the most important to the least important. Then, the cumulative proportion of plants (x-axis) is plotted against the corresponding cumulative proportion of their total size on the y-axis. If all individuals are the same size or each element has an equal value in its shares of X and Y, the Lorenz curve is a straight diagonal line, called the line of perfect equality, but if there is any inequality in size or one element has the total cumulative percentage of Y while the others have none, the Lorenz curve is below this line (Damgaard and Weiner 2000).

The objective of multicollinearity test is to see whether there is a strong relationship between each independent variable. If there is so, it means that there is a problem of perfect correlation as assumed that there must be no perfect correlation in the multiple regression models. This problem will make us difficult to estimate the regression coefficients, since the values of the variance and fix error for each coefficient are so high leading to the inaccuracy of the model. One alternative solution is to reduce one independent variable and construct the new model, add the data, or choose the new sample. One way to determine the existence of multicollinearity is the high value of correlation coefficients between each independent variable, which is more than 0.8 (Pindyck and Rubinfeld 1997).

The assumption of non-multicollinearity means that errors corresponding to different observations are independent and uncorrelated. When the error terms from different observations are correlated, we say that there is an auto-correlation of the error process²⁴. This results in the biased estimated coefficient and the unreal resulted value of the variance. In the end, this affects the model efficiency, which leads to the acceptance of the null hypothesis.

The next assumption that must be fulfilled is the constant variance of the error term (homoscedastic). If the variance is changing (called the error heteroscedastic), the t test result will be unuseful. In order to see the existence of heteroscedasticity, we construct the hypothesis as follow:

- $H_0 : b = 0$; The regression coefficient of each independent variable is not significant, which means that there is no heteroscedasticity (called homoscedasticity)
- $H_1 : b \neq 0$; The regression coefficient of each independent variable is significant, which means that there is a heteroscedasticity.

The Hausman Test

By using Hausman test, we find that there is a trade-off between the bias and the efficiency of the estimation result. In the fixed effects model, the estimation result shows unbiased and inefficient result, while in the GLS the result will be biased and efficient.

²⁴ Ibid.

For example: in the linear model $y = bX + e$, where y is univariate and X is vector of regressors, b is a vector of coefficients and e is the error term. We have two estimators for b , b_0 and b_1 . Under the null hypothesis, both of these estimators are consistent, but b_1 is more efficient (has smaller asymptotic variance) than b_0 . Under the alternative hypothesis, one or both of these estimators is inconsistent. Thus, we can derive the statistic:

$$H = T(b_0 - b_1)' \text{Var}(b_0 - b_1)^{-1} (b_0 - b_1),$$

Where: T is the number of observations. This statistic has chi-square distribution (χ^2) with k (length of b) degrees of freedom.

Hence, the hypotheses are made as followed:

- H_0 : GLS estimator $\hat{\beta}$ is better than the fixed effect (full) model estimator b^f (the random effects estimation is correct)
- H_1 : The fixed effect (full) model estimator b^f is better than GLS estimator $\hat{\beta}$ (the fixed effects estimation is correct)

Under these hypotheses, the null hypothesis underlies that the fixed effect model (FEM) and error correction model (ECM) estimators do not differ substantially. When a Hausman test rejects, we know only that the model at issue is misspecified, and the conclusion is that ECM is not appropriate and that we may be better off using FEM.

ANNEX II

Annex II-a
Total Production of Fishery Commodities by Province, 2000-2004

Unit: Tonnes

NO.	PROVINCE	YEAR				
		2000	2001	2002	2003	2004
1	N. Aceh Darussalam	113,096	120,831	120,708	168,917	139,620
2	North Sumatera	380,901	386,634	400,798	396,864	376,660
3	West Sumatera	123,524	130,587	117,928	136,663	147,460
4	Riau	308,811	337,015	349,372	364,436	358,640
5	Jambi	50,821	56,173	56,913	63,558	62,417
6	South Sumatera	222,948	118,502	127,695	161,568	162,950
7	Bengkulu	33,599	35,064	33,814	39,137	38,552
8	Lampung	189,146	191,833	193,347	214,688	244,367
9	Bangka Belitung	0	128,169	136,841	144,673	144,797
10	DKI Jakarta	106,164	108,737	108,269	127,054	127,647
11	West Java	436,803	399,902	405,337	385,466	433,302
12	Central Java	346,834	376,322	381,930	348,229	342,550
13	D.I. Yogyakarta	6,939	6,532	7,847	10,502	8,782
14	East Java	435,937	446,669	554,084	576,945	490,669
15	Banten	0	129,741	87,835	81,889	76,438
16	Bali	166,502	168,755	196,356	210,456	227,082
17	West Nusa Tenggara	120,874	124,347	123,642	132,618	133,087
18	East Nusa Tenggara	94,843	106,178	116,262	102,276	163,698
19	West Kalimantan	81,063	80,459	80,947	79,449	80,245
20	Central Kalimantan	91,339	93,707	95,278	78,751	78,170
21	South Kalimantan	161,496	163,430	169,424	173,619	173,721
22	East Kalimantan	121,121	134,227	134,149	136,908	168,493
23	North Sulawesi	203,500	198,884	212,946	207,009	213,221
24	Central Sulawesi	116,437	103,475	91,473	106,179	109,923
25	South Sulawesi	468,392	469,747	481,176	511,873	488,519
26	Southeast Sulawesi	166,675	183,498	194,969	213,092	290,604
27	Gorontalo	0	34,096	38,029	40,312	43,288
28	Maluku	362,468	218,885	171,798	373,882	428,210
29	North Maluku	0	84,643	105,260	77,951	80,643
30	Papua	209,319	214,380	220,762	249,465	281,702
	TOTAL	5,119,552	5,351,422	5,515,189	5,914,429	6,115,457

Source: Marine and Fishery Statistics 2005, Ministry of Marine Affairs and Fisheries

Annex II-b
Number of Fish Production in East Java and South Sulawesi, 2000-2004

Province	Year	The Production (Ton)			Total
		Marine	Inland Open-water	Aquaculture	
East Java	2000	298,068	16,093	121,776	435,937
	2001	296,418	16,315	133,936	446,669
	2002	394,586	17,288	142,210	554,084
	2003	414,653	17,623	144,669	576,945
	2004	320,691	16,113	153,865	490,669
South Sulawesi	2000	309,890	25,250	133,252	468,392
	2001	306,115	26,668	136,964	469,747
	2002	337,042	22,258	121,876	481,176
	2003	354,399	22,412	135,062	511,873
	2004	314,678	19,947	153,894	488,519

Source: Marine and Fishery Statistics, 2005, Ministry of Marine Affairs and Fisheries

Annex II-c
The Volume of Marine Fishery Products by Type of Production

Unit: Tonnes

Province	Year	Dried/Salted	Boiled	Fermentation	Smoked	Frozen
East Java	2000	43,524	24,831	1,338	3,636	10,285
	2001	56,108	47,216	1,270	7,099	16,495
	2002	62,684	42,690	3,408	8,168	13,747
	2003	71,335	37,550	2,797	5,135	7,178
	2004	36,615	42,101	2,124	7,915	8,836
	Year	Canned	Fishmeal	Other Processed	Total	
	2000	1,415	374	1,645	87,048	
	2001	2,285	2,926	5,283	138,682	
	2002	3,276	4,657	36,814	175,444	
	2003	5,515	2,869	41,949	174,328	
2004	4,383	3,238	4,824	110,036		
South Sulawesi	Year	Dried/Salted	Boiled	Fermentation	Smoked	Frozen
	2000	42,595	4,620	10	4,724	5,016
	2001	51,400	2,584	18	1,616	781
	2002	47,758	7,727	9	5,058	1,027
	2003	54,018	5,499	7	6,976	1,077
	2004	33,383	5,597	848	6,610	2,996
	Year	Canned	Fishmeal	Other Processed	Total	
	2000	0	0	0	56,965	
	2001	0	0	256	56,655	
	2002	0	0	260	61,839	
2003	78	0	0	67,655		
2004	0	40	0	49,474		

Source: Marine and Fishery Statistics 2005, Ministry of Marine Affairs and Fisheries

Annex II-d
The Volume of Inland Open-water Fishery Products by Type of Production

Unit: Tonnes

Province	Year	Dried/Salted	Boiled	Fermentation	Smoked	Frozen	Other Processed	Total
East Java	2000	103	0	0	210	103	16	432
	2001	784	0	22	587	190	289	1,872
	2002	1,831	43	23	912	491	127	3,427
	2003	797	70	29	797	383	237	2,313
	2004	894	0	3	585	254	250	1,986
South Sulawesi	2000	4,467	0	0	41	0	0	4,508
	2001	3,893	0	0	62	0	1	3,956
	2002	2,977	2	0	156	0	0	3,135
	2003	5,277	26	0	43	0	0	5,346
	2004	2,469	42	14	92	0	3	2,620

Source: Marine and Fishery Statistics 2005, Ministry of Marine Affairs and Fisheries

Annex II-e
Export Volume of Fishery Products by Province, 2000-2004

Unit: Tonnes

NO.	PROVINCE	YEAR				
		2000	2001	2002	2003	2004
1	Nanggroe Aceh Darussalam	35	4	158	471	415
2	North Sumatera	49,911	59,701	56,427	54,941	58,782
3	West Sumatera	644	45	111	45	32
4	Riau	48,932	38,748	32,555	37,657	32,748
5	Jambi	2,727	3,729	2,626	3,974	2,664
6	South Sumatera	2,256	1,731	1,946	2,367	3,001
7	Bengkulu	9	0	0	0	1
8	Lampung	9,241	5,039	10,063	17,427	15,832
9	Bangka Belitung	4,807	3,895	3,121	3,197	4,192
10	DKI Jakarta	85,581	92,068	91,162	92,598	103,289
11	West Java	99	39	275	52	61

Universitas Indonesia

Annex II-e (Continued)

NO.	PROVINCE	YEAR				
		2000	2001	2002	2003	2004
12	Central Java	8,867	8,681	11,433	14,770	21,690
13	D.I. Yogyakarta	0	38	73	0	0
14	East Java	149,988	173,907	196,491	225,819	234,112
15	Banten	0	9	0	4,099	3,988
16	Bali	18,803	19,609	17,810	15,126	12,439
17	West Nusa Tenggara	1	0	10	22	657
18	East Nusa Tenggara	1736	899	1495	413	685
19	West Kalimantan	3,797	3,608	3,742	3,447	3,026
20	Central Kalimantan	107	145	67	57	58
21	South Kalimantan	2,723	2,974	1,948	1,374	1,729
22	East Kalimantan	6,602	7,645	7,557	7,964	9,684
23	North Sulawesi	54149	8208	23707	64222	114908
24	Central Sulawesi	286	608	537	244	9
25	South Sulawesi	27,168	28,640	26,561	25,214	30,640
26	Southeast Sulawesi	2,933	4,521	5,597	2,612	1,458
27	Gorontalo	837	184	900	593	10
28	Maluku	0	0	56,830	142,900	208,802
29	North Maluku	4,246	1,095	692	1,174	1,456
30	Papua	32,934	21,344	11,847	135,004	35,992
	TOTAL	519,419	487,114	565,741	857,783	902,360

Source: Ministry of Marine Affairs and Fisheries, 2006

Annex II-f
The Volume and Value of Export and Import of Fishery Commodities
in East Java and South Sulawesi, 2000-2004

Province	Year	Export		Import	
		Volume (Ton)	Value (000 US\$)	Volume (Ton)	Value (US\$)
East Java	2000	149,988	600,226	53,502.2	39,749,377
	2001	173,907	598,627	39,385.9	32,633,446
	2002	196,491	567,091	25,233.7	25,925,429

Annex II-f (Continued)

Province	Year	Export		Import	
		Volume (Ton)	Value (000 US\$)	Volume (Ton)	Value (US\$)
East Java	2003	225,819	594,022	22,749.6	25,728,016
	2004	234,112	688,119	38,600.8	77,848,059
South Sulawesi	2000	27,168	116,384	35.261	15,568
	2001	28,640	113,842	41.740	83,986
	2002	26,561	108,286	8.581	21,427
	2003	25,214	82,531	363.615	5,604
	2004	30,640	82,506	129.628	203,637

Source: Marine and Fishery Statistics, 2005, Ministry of Marine Affairs and Fisheries

Annex II-g
Export Volume and Value of Fishery Products Based on Type of Commodities
in East Java and South Sulawesi, 2003 – 2004

No.	Type of Fish Commodity	EAST JAVA		SOUTH SULAWESI	
		2003	2004	2003	2004
1	Fresh or Frozen Fish (Alive or non-alive)				
	Volume (kg):	75,374,947	76,684,449	3,758,567	5,028,375
	Value (US\$)	86,928,901	92,660,174	11,440,655	15,624,165
2	Dried/salted/smoked Fish				
	Volume (kg):	8,251,404	7,330,092	284,821	410,133
	Value (US\$)	28,699,526	32,581,929	1,314,049	1,551,985
3	Alive, fresh, frozen, dried, salted, boiled crustaceans and molluscs				
	Volume (kg):	61,560,732	55,350,176	8,723,741	7,770,477
	Value (US\$)	352,275,548	345,614,234	61,698,063	56,460,775
4	Processed and preserved fish, crustaceans, and molluscs in dense or non-dense package				
	Volume (kg):	33,446,489	46,632,313	216,720	176,572
	Value (US\$)	91,678,943	182,928,871	3,301,254	2,442,616

Annex II-g (Continued)

No.	Type of Fish Commodity	EAST JAVA		SOUTH SULAWESI	
		2003	2004	2003	2004
5	Oil and Fat from Fishery Commodity				
	Volume (kg):	344,081	730,774	0	0
	Value (US\$)	483,730	308,772	0	0
6	Fishery Production for non food-fish meal				
	Volume (kg):	7,545,858	4,003,896	84,000	0
	Value (US\$)	3,028,015	1,419,018	2,520	0
7	Other fishery products				
	Volume (kg):	8,060,738	7,485,162	1,197,590	905,279
	Value (US\$)	13,782,107	12,417,528	593,399	629,997
8	Water Plant				
	Volume (kg):	31,234,625	35,894,801	10,949,002	16,349,371
	Value (US\$)	17,145,586	20,188,178	4,180,605	5,796,258

Source: Ministry of Marine Affairs and Fisheries, 2006

Annex II-b
The Composition of Exports from East Java, 2002 and 2004

Commodity Group	2002 (US\$ Millions)	2004 (US\$ Millions)
Primary :	700	679.7
Coffee, Rubber, Tobacco, Tea	108	111.4
Seafoods	411	480.8
Other Primary	182	87.5
Manufactures :	4,567	4,072.6
• Food, drink, tobacco	476	206.8
• Textiles, clothing, footwear	447	353.7
• Plywood	154	394.7
• Paper & Paperboard	745	579.7
• Furniture	221	334
• Chemicals, Pharmaceuticals, Plastics	1,181	1,102.2

Annex II-h (Continued)

Commodity Group	2002 (US\$ Millions)	2004 (US\$ Millions)
• Electronics Equipment	103	123
• Others & unspecified	1,077	650
Total	5,276	4,752.3

Source: BPS, Indonesia Foreign Trade Statistics 2002, Bank of Indonesia, Santosa & McMichael (2004)

Annex II-i
The List of Exporting Companies in East Java

No.	Product Category	Location
1	Crab in Airtight Containers	Pasuruan
2	Crabs, Fresh or Chilled	Waru, Sidoarjo
3	Cuttle-Fish Frozen	Industrial Zone, Rungkut, Surabaya Beji, Pasuruan
4	Cuttle Fish Live, Fresh or Frozen	Industrial Zone, Rungkut, Surabaya
5	Fish Extracts	Gempol, Pasuruan
6	Fish, dried, salted etc, smoked etc, fish meal	Waru, Sidoarjo
7	Fish, frozen	Surabaya Sidoarjo Industrial Zone, Gresik
8	Fishery/Marine Products	Surabaya Sidoarjo
9	Kerupuk of Shrimps	Sidoarjo
10	Mackerel Prepared or Preserved	Industrial Zone, Rungkut, Surabaya
11	Octopus Frozen	Industrial Zone, Rungkut, Surabaya
12	Octopus Live, Fresh or Chilled	Industrial Zone, Rungkut, Surabaya
13	Other Prepared of Preserved Fish	Beji, Pasuruan
14	Salmon in Airtight Containers	Beji, Pasuruan
15	Seaweeds	Buduran, Sidoarjo

Annex II-i (Continued)

No.	Product Category	Location
16	Shrimps, Fresh & Frozen	Beji, Pasuruan Malang Waru, Sidoarjo Gadangan, Sidoarjo Gempol, Pasuruan Sidoarjo
17	Shrimps & Prawn Prepared or Preserved	Beji, Pasuruan
18	Tuna	Industrial Zone, Rungkut, Surabaya Beji, Pasuruan
19	Tuna, Skipjack & Bonito in Air Tight Containers	Gempol, Pasuruan Beji, Pasuruan
20	Tuna, Skipjack in Other Containers	Gempol, Pasuruan

Source: Trade Database, National Agency for Export Development

Annex II-j
The List of Exporting Companies in South Sulawesi

No	Product Category	Location
1	Crabs, Fresh or Chilled	Makassar City
2	Fish fillets and other fish meat	Industrial Zone (KIMA)
3	Fish, Fresh or Chilled	Makassar City Industrial Zone (KIMA)
4	Fish, frozen	Industrial Zone (KIMA), Makassar
5	Fishery/Marine Products	Gowa, Makassar Makassar City (4 locations)
6	Fishing Rods	Makassar
7	Octopus Frozen	Industrial Zone (KIMA)
8	Octopus Live, Fresh or Chilled	Industrial Zone (KIMA)
9	Sea Shell	Makassar
10	Seaweeds	Makassar City (2 locations)
11	Shrimps (Fresh, Frozen)	Makassar City (4 locations) Industrial Zone (KIMA) - 6 locations

Annex II-j (Continued)

No	Product Category	Location
12	Tuna	Industrial Zone (KIMA) Makassar City

Source: Trade Database, National Agency for Export Development

Annex II-k
Export Commodity of South Sulawesi, 2001-2002

No.	Type of Commodity	2001		2002	
		Value (US\$ Million)	Percent (%)	Value (US\$ Million)	Percent (%)
1	Cacao and its processed products	176.5	31.38	340.9	63.72
2	Dairy products, egg, poultry, and natural honey	208.6	37.08	104.1	19.46
3	Wood, wood-based products and wood-based coal	29.1	5.17	20.4	3.81
4	Salt, sulphur, soil, stone, plaster material, limestone and cement	72.6	12.91	18.8	3.51
5	Coffee, tea, cashew and spices	8.7	1.55	10.8	2.02
6	Stone-based products, gypsum, cement, mica, etc	6.3	1.12	7.8	1.46
7	Fruit, shelled fruit, orange peel	13.7	2.44	4.2	0.79
8	Others	47.0	8.36	28	5.23
	TOTAL	562.5	100	535	100

Source: South Sulawesi in Figures, Central Bureau of Statistics 2002

Annex II-I
The Value of Export Commodity of South Sulawesi, 2003-2004

No.	Type of Commodity (SITC Code)	2003		2004	
		Value (Thousand US\$)	Percent. (%)	Value (Thousand US\$)	Percent. (%)
1	Metalliferous ores and Metal Scrap	159,251	29.87	798,119	62.11
2	Coffee, Tea, Cocoa, Spices	216,779	40.65	233,923	18.20
3	Fish, Crustacea, Molluses and their Preparations	75,935	14.24	92,969	7.24
4	Wood and Cork Manufactures	16,801	3.15	28,032	2.18
5	Non Metallic Minerals Mfs	18,701	3.51	7,846	0.61
6	Fixed Vegetable Oils and Fats	17,446	3.27	23,151	1.80
7	Crude Animal and Vegetable Material	6,161	1.16	8,508	0.66
8	Wood, Lumber and Cork	4,403	0.83	10,369	0.81
9	Crude Rubber	4,350	0.82	7,793	0.61
10	Cereal and Cereal Preparations	1,599	0.30	4,161	0.32
11	Others	13,403	2.51	74,279	5.78
	TOTAL	533,230	100	1,284,989	100

Source: Bank of Indonesia, 2006

Annex II-m
Number of Fish Processing Firms by Province, 2000 – 2004

NO.	PROVINCE	YEAR				
		2000	2001	2002	2003	2004
1	N. Aceh Darussalam	1	1	0	0	0
2	North Sumatera	41	37	35	31	31
3	Riau	12	12	0	10	10
4	South Sumatera	15	15	7	4	4
5	Bengkulu	0	0	0	1	0
6	Lampung	3	3	3	3	3
7	Bangka Belitung	0	0	9	8	8
8	DKI Jakarta	15	44	39	40	43
9	West Java	16	17	19	19	16

Universitas Indonesia

Annex II-m (Continued)

NO.	PROVINCE	YEAR				
		2000	2001	2002	2003	2004
10	Central Java	109	128	113	111	77
11	D.I. Yogyakarta	1	0	0	1	1
12	East Java	201	199	196	167	161
13	Banten	0	0	1	1	1
14	Bali	10	12	13	11	9
15	East Nusa Tenggara	1	2	1	2	4
16	West Kalimantan	6	6	6	6	5
17	Central Kalimantan	1	1	1	1	1
18	South Kalimantan	6	7	6	5	7
19	East Kalimantan	9	11	11	12	13
20	North Sulawesi	17	15	18	13	14
21	Central Sulawesi	1	1	1	0	0
22	South Sulawesi	18	18	20	22	20
23	Southeast Sulawesi	9	14	20	21	21
24	Gorontalo	0	0	6	8	8
25	Maluku	6	5	5	7	7
26	North Maluku	1	1	1	0	0
27	Papua	13	14	5	3	2
	TOTAL	512	563	536	507	466

Source: Directory of Industries 2000-2004, Statistics of Indonesia

Annex II-n
Number of Person Engaged in The Fish Processing Industries by Province
2000 – 2004

Unit: Persons

NO.	PROVINCE	YEAR				
		2000	2001	2002	2003	2004
1	N. Aceh Darussalam	128	128	-	-	-
2	North Sumatera	5,577	4,734	5,782	6,253	6,075
3	Riau	559	559	-	698	692
4	South Sumatera	3,788	1,792	1,702	1,179	1,179
5	Bengkulu	-	-	-	98	-
6	Lampung	4,048	7,115	14,719	15,089	15,089
7	Bangka Belitung	-	-	573	476	488
8	DKI Jakarta	3,244	6,017	4,169	4,546	4,643
9	West Java	1,659	2,558	3,276	3,174	2,605
10	Central Java	7,167	8,252	7,408	7,553	5,832
11	D.I. Yogyakarta	301	-	-	138	138

Universitas Indonesia

Annex II-n (Continued)

NO.	PROVINCE	YEAR				
		2000	2001	2002	2003	2004
12	East Java	26,454	24,590	22,681	21,163	22,310
13	Banten	-	-	174	174	174
14	Bali	1,986	1,764	1,885	1,900	1,814
15	East Nusa Tenggara	51	82	70	92	217
16	West Kalimantan	615	700	700	766	864
17	Central Kalimantan	105	111	111	118	118
18	South Kalimantan	1,160	1,913	1,842	1,513	1,940
19	East Kalimantan	2,580	4,106	4,423	4,370	4,536
20	North Sulawesi	3,170	5,067	4,480	3,191	3,796
21	Central Sulawesi	45	45	43	-	-
22	South Sulawesi	3,634	3,984	4,608	4,922	4,453
23	Southeast Sulawesi	3,379	3,142	2,550	2,296	2,516
24	Gorontalo	-	-	265	423	513
25	Maluku	422	258	258	460	460
26	North Maluku	21	-	-	-	-
27	Papua	6,708	6,650	1,489	1,554	1,173
	TOTAL	76,801	83,591	83,232	82,146	81,625

Source: Marine and Fishery Statistics 2005, Ministry of Marine Affairs and Fisheries

Annex II-o

The Distribution of Fish Processing Firms by Regencies in East Java, 2000 – 2004

No.	Regions In East Java	Year				
		2000	2001	2002	2003	2004
1	Pasuruan	14	17	21	21	22
2	Banyuwangi	28	23	24	24	23
3	Lamongan	34	34	34	31	31
4	Sumenep	26	35	28	22	20
5	Situbondo	17	17	19	18	18
6	Tuban	19	17	18	18	15
7	Bangkalan	9	9	8	8	9
8	Gresik	3	3	2	3	3
9	Probolinggo	4	3	3	2	2
10	Pamekasan	1	1	1	1	1
11	Surabaya	5	4	5	5	5
12	Malang	1	1	1	1	1
13	Sidoarjo	10	9	8	8	7
14	Trenggalek	24	25	24	24	25

Universitas Indonesia

Annex II-o (Continued)

No.	Regions In East	Year				
	Java	2000	2001	2002	2003	2004
15	Jember	2	2	2	3	2
16	Mojokerto	1	1	1	1	1
17	Kediri	1	0	1	1	1
18	Sampang	2	1	1	1	1
19	Bojonegoro	1	1	0	0	0
	TOTAL	202	203	201	192	187

Source: Directory of Industries 2000-2004, Statistics of Indonesia

Annex II-p
The Summary of Major Differences Between East Java and South Sulawesi

No.	Factor	East Java	South Sulawesi
1	The division of growth corridors	There are four development corridors: North-South, South-Western, Eastern, & Northern Corridors	There is one integrated development zone: Parepare Integrated Economic Development Zone (IEDZ)
2	Industrial Zone	<ul style="list-style-type: none"> • Surabaya Industrial Estate Rungkut (SIER): 476 ha • Pasuruan Industrial Estate Rembang (PIER): 500 ha, in Pasuruan, Sidoarjo, Probolinggo • Ngoro Industri Persada (NIP), in Mojokerto • Maspion Industrial Zone (KIM) in Surabaya and Gresik 	<ul style="list-style-type: none"> • Makassar Industrial Zone (KIMA): 233.96 ha, planned to be developed up to 703 ha • Export Processing Zone • City Warehouse & Cargo Storage
3	Manufacturing industries Area	<ul style="list-style-type: none"> • Surabaya – Malang corridor: Gresik, Sidoarjo, Pasuruan, Mojokerto • Banyuwangi: medium industry producing articles for tourism • Pacitan: souvenir manufacturing • Tulungagung: garments exporter & manufacture of marble • Sidoarjo: leather goods' exporter 	<ul style="list-style-type: none"> • Makassar city • Parepare city • Regencies: Barru, Pinrang, Sidrap, & Enrekang
	Fishery industries Area	<ul style="list-style-type: none"> • Lamongan, Banyuwangi, Sumenep, Trenggalek, Pasuruan, Sidoarjo, Surabaya 	Makassar

Annex II-p (Continued)

No.	Factor	East Java	South Sulawesi
4	Local Government Policy	<ul style="list-style-type: none"> • Social & economic policies : professional bureaucracy and perceived legitimacy of the provincial administration • In 1984, introducing Master Plan for the development of manufacturing industry in East Java 	<ul style="list-style-type: none"> • Import duty exemption for machines, major equipments, & basic commodities • Exemption of ownership's title transfer tax • Income tax exemption • Exemption of land & building tax by 50% for 8 years
5	Infrastructures	Total road length in: 2000: 49,492.37 km 2004: 49,608.09 km	Total road length in: 2000: 29,805.13 km 2004: 30,111.06 km
6	Transportation Facilities	<ul style="list-style-type: none"> • 1 unit major harbour • 1 unit international container terminal in Surabaya • 2 units medium ports • 4 units small local ports • 1 cargo terminal in Jember regency • 1 international airport 	<ul style="list-style-type: none"> • 1 unit major harbour • 4 unit small harbour • 1 unit container terminal in Makassar • 1 international airport
7	Operational Activities in General Harbor (the volumes of export, import, cargo loading & unloading)	2000: 8,251,787 tonnes 2004: 11,436,695 tonnes	2000: 6,216,514 tonnes 2004: 8,964,875 tonnes
8	Investment: Total Sector	2000: <ul style="list-style-type: none"> • Domestic: 3,409.16 million US\$ • Foreign: 1,113.6 million US\$ 2004: <ul style="list-style-type: none"> • Domestic: 3,801.76 million US\$ • Foreign: 325.1 million US\$ 	2000: <ul style="list-style-type: none"> • Domestic: 35,479.69 million US\$ • Foreign: 36,5 million US\$ 2004: <ul style="list-style-type: none"> • Domestic: 723.57 million US\$ • Foreign: 311.7 million US\$
	Fishery Sector	Foreign: <ul style="list-style-type: none"> • 2000: 651,000 million US\$ • 2004: 2,000,000 million US\$ 	Foreign: <ul style="list-style-type: none"> • 2000 & 2004: - • 2003: 370,000 million US\$
9	Banking facility (domestic, foreign, & joint venture banks)	Number of offices of Banks and Finance Companies: 2,320 units	Number of offices of Banks and Finance Companies: 488 units

Annex II-p (Continued)

No.	Factor	East Java	South Sulawesi
10	Type of Commodity Mostly Exported	In 2002 & 2004: <ul style="list-style-type: none"> • Chemicals, pharmaceuticals, plastics • Paper & paperboard • Seafoods 	In 2002: <ul style="list-style-type: none"> • Cacao & its processed products • Dairy products, egg, poultry, & natural honey In 2004: <ul style="list-style-type: none"> • Metalliferous ores & metal scrap • Coffee, tea, cocoa, spices • Seafood products: fish, shrimp, & other marine commodities
11	Number of Fish Processing Firms	2000: 201 unit 2004: 161 unit	2000: 18 unit 2004: 20 unit
12	Number of Employment Working on Fish Processing Firms	2000: 26,454 persons 2004: 22,310 persons	2000: 3,634 persons 2004: 4,453 persons
13	The Total Volume of Fish Production	2000: 435,937 tonnes 2004: 490,669 tonnes	2000: 468,392 tonnes 2004: 488,519 tonnes
14	The Volume of Export and Import of Fishery Commodities	2000: <ul style="list-style-type: none"> • Export: 149,988 tonnes • Import: 53,502 tonnes 2004: <ul style="list-style-type: none"> • Export: 234,112 tonnes • Import: 38,600 tonnes 	1. 2000: <ul style="list-style-type: none"> • Export: 27,168 tonnes • Import: 35,261 tonnes 2004: <ul style="list-style-type: none"> • Export: 30,640 tonnes • Import: 129,628 tonnes
15	Industrial Development Constraints	<ul style="list-style-type: none"> • Poor road maintenance • Difficult access to industrial estates • The development of physical infrastructure did not spread evenly throughout all reg • Insufficient power and water supply 	<ul style="list-style-type: none"> • Lack of up to date information • Lower incentives from local government • Long bureaucracy & high economic costs resulting from extra unofficial tax collection • Land conflict • Political & social instability

Source: Based on Author's Analysis

between = 0.3343 avg = 5.0
 overall = 0.3429 max = 5
 Random effects u_i ~ Gaussian Wald chi2(7) = 110.62
 corr(u_i, X) = 0 (assumed) Prob > chi2 = 0.0000

sfshemp	Coef.	Std. Err.	z	P> z	[95% Conf. Interval]	
sgdpf	-.0004473	.0002391	-1.87	0.061	-.0009159	.0000213
empdens	2.97e-08	2.98e-09	9.95	0.000	2.38e-08	3.55e-08
prod	-7.19e-12	2.95e-11	-0.24	0.808	-6.51e-11	5.07e-11
presvprod	1.83e-11	4.04e-11	0.45	0.651	-6.09e-11	9.74e-11
infrarea	2.48e-06	3.15e-06	0.79	0.431	-3.69e-06	8.65e-06
harbor	-1.50e-13	1.43e-13	-1.05	0.293	-4.31e-13	1.30e-13
fishport	6.49e-07	3.58e-07	1.82	0.070	-5.18e-08	1.35e-06
_cons	.0000289	.0000191	1.51	0.131	-8.56e-06	.0000663
sigma_u		.00004199				
sigma_e		.00001082				
rho		.93775491	(fraction of variance due to u _i)			

C. The Hausman Test

Note: the rank of the differenced variance matrix (3) does not equal the number of coefficients being tested (7); be sure this is what you expect, or there may be problems computing the test. Examine the output of your estimators for anything unexpected and possibly consider scaling your variables so that the coefficients are on a similar scale.

	— Coefficients —			
	(b) fixed	(B) random	(b-B) Difference	sqrt(diag(V_b-V_B)) S.E.
sgdpf	-.0007835	-.0004473	-.0003362	.0003757
empdens	3.21e-08	2.97e-08	2.46e-09	5.58e-10
prod	-3.05e-11	-7.19e-12	-2.33e-11	1.09e-11
presvprod	2.71e-11	1.83e-11	8.82e-12	

infraarea	6.23e-06	2.48e-06	3.75e-06	5.08e-06
harbor	-2.95e-13	-1.50e-13	-1.45e-13	3.90e-14
fishport	-2.89e-06	6.49e-07	-3.54e-06	1.56e-06

b = consistent under Ho and Ha; obtained from xtreg

B = inconsistent under Ha, efficient under Ho; obtained from xtreg

Test: Ho: difference in coefficients not systematic

$$\begin{aligned} \text{chi2}(3) &= (b-B)'[(V_b-V_B)^{-1}](b-B) \\ &= 5.80 \end{aligned}$$

$$\text{Prob}>\text{chi2} = 0.1219$$

(V_b-V_B is not positive definite)

D. Testing The Correlation Between Dependent and Independent Variables

	sfishemp	sgdpf	empdens	prod	presvprod	infraarea	harbor	fishport
sfishemp	1.0000							
sgdpf	-0.3169*	1.0000						
empdens	0.3705*	-0.3169*	1.0000					
prod	0.5663*	-0.0863	0.0597	1.0000				
presvprod	0.3685*	0.2170*	-0.0041	0.6241*	1.0000			
infraarea	0.0811	-0.2553*	-0.0591	-0.0316	-0.1195	1.0000		
harbor	0.0793	-0.3214*	0.0455	0.0312	-0.1001	0.0482	1.0000	
fishport	0.3771*	-0.2749*	-0.1006	0.2852*	0.0981	-0.0942	-0.1279	1.0000

E. Testing The Autocorrelation and Heteroskedasticity

Coefficients : generalized least squares

Panels : homoskedastic

Correlation : no autocorrelation

Estimated covariances	=	1	Number of obs	=	135
Estimated autocorrelations	=	0	Number of groups	=	27
Estimated coefficients	=	8	Time periods	=	5
			Wald chi2(4)	=	80.70
Log likelihood	=	1181.172	Prob > chi2	=	0.0000

Universitas Indonesia

sfishemp	Coef.	Std. Err.	z	P> z	[95% Conf. Interval]	
sgdpf	-.0003883	.0001198	-3.24	0.001	-.0006232	-.0001534
empdens	2.91e-08	4.36e-09	6.67	0.000	2.05e-08	3.76e-08
prod	1.34e-10	3.17e-11	4.22	0.000	7.15e-11	1.96e-10
presvprod	2.11e-10	7.92e-11	2.67	0.008	5.60e-11	3.66e-10
Infrarea	2.50e-06	1.42e-06	1.76	0.079	-2.86e-07	5.29e-06
harbor	7.75e-14	1.66e-13	0.47	0.641	-2.48e-13	4.03e-13
fishport	5.99e-07	1.51e-07	3.97	0.000	3.03e-07	8.95e-07
_cons	-.0000109	.0000101	-1.09	0.276	-.0000307	8.76e-06

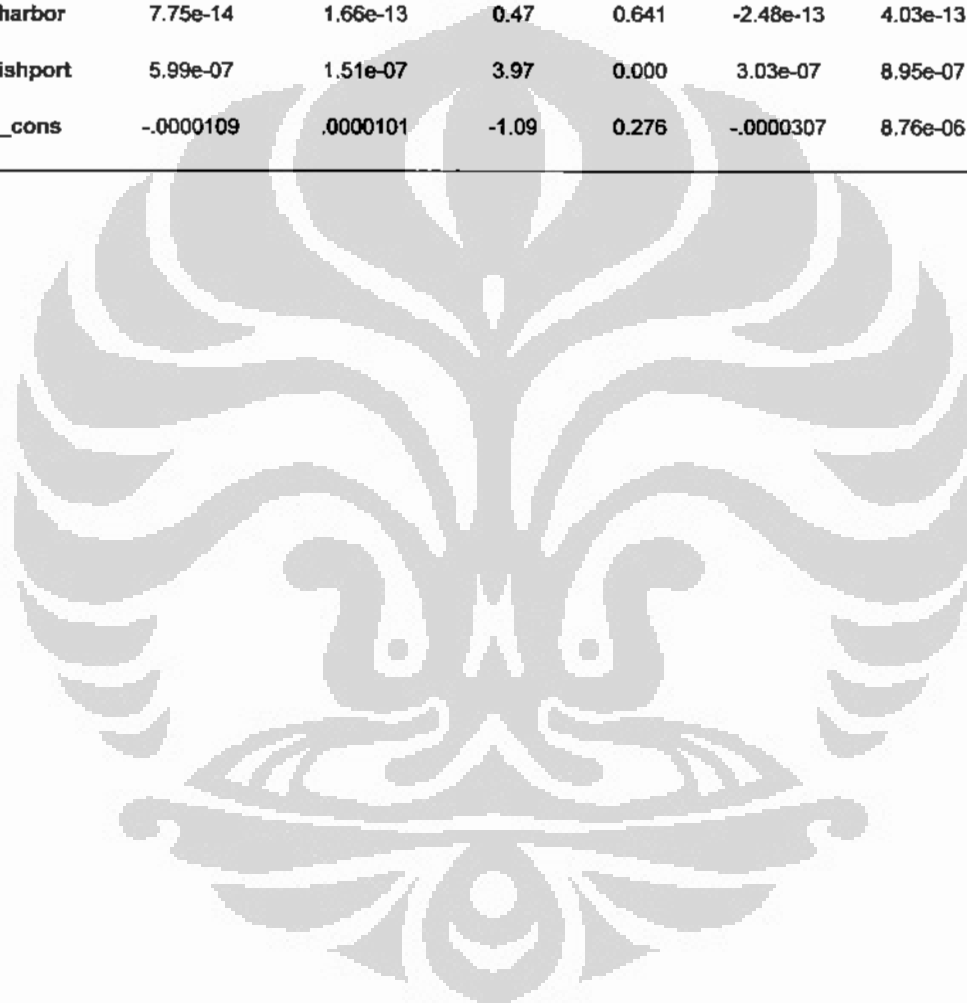

ANNEX IV

The Dependent and Independent Variables Used in The Panel Data Regression

PROVINCE	id	YEAR	SFISHEMP	SGDPF	SPROC	EMPDENS	PROD	PRESV- PROD	INFAREA	HARBOR	FISH PORT
NAD	1	1	1.592E-06	0.0289	0.0538	128	113,096	6,551	0.4697	20,559,369	66
NAD	1	2	1.475E-06	0.0327	0.0407	128	120,831	8,676	0.5158	18,238,356	66
NAD	1	3	0.000E+00	0.0277	0.0536	0	120,708	3,049	0.5175	16,179,370	66
NAD	1	4	0.000E+00	0.0272	0.0514	0	168,917	6,747	0.5154	16,482,683	67
NAD	1	5	0.000E+00	0.0303	0.0450	0	139,620	4,301	0.5229	14,927,833	67
NS	2	1	7.017E-05	0.0317	0.2435	138	380,901	60,031	0.5394	10,111,271	25
NS	2	2	5.416E-05	0.0308	0.2439	127	386,634	151,576	0.5394	11,200,203	26
NS	2	3	6.617E-05	0.0305	0.2447	165	400,798	112,792	0.5272	12,406,406	26
NS	2	4	7.114E-05	0.0286	0.2436	202	396,864	93,269	0.5428	12,742,530	27
NS	2	5	6.949E-05	0.0259	0.2428	196	376,660	93,318	0.5493	15,916,763	27
RIAU	3	1	6.951E-06	0.0172	0.1905	47	308,811	52,055	0.1793	49,118,573	8
RIAU	3	2	6.440E-06	0.0184	0.2057	47	337,015	52,833	0.1793	48,188,615	8
RIAU	3	3	0.000E+00	0.0191	0.2143	0	349,372	23,095	0.1755	47,286,813	9
RIAU	3	4	8.150E-06	0.0199	0.2218	72	364,436	42,693	0.1794	45,770,300	9
RIAU	3	5	7.915E-06	0.0206	0.2310	69	358,640	49,337	0.1840	45,202,659	10
SS	4	1	2.140E-05	0.0276	0.1210	115	222,948	11,318	0.2859	11,042,785	1
SS	4	2	1.338E-05	0.0282	0.1228	77	118,502	8,310	0.2859	10,847,937	1
SS	4	3	1.948E-05	0.0284	0.1234	243	127,695	11,199	0.2671	10,656,527	1
SS	4	4	1.336E-05	0.0285	0.1248	295	161,568	17,629	0.2633	11,020,711	2
SS	4	5	1.349E-05	0.0284	0.1285	295	162,950	9,948	0.2636	11,008,936	2
BENGGKULU	5	1	0.000E+00	0.0845	0.0399	0	33,599	92	0.6376	-	40
BENGGKULU	5	2	0.000E+00	0.0864	0.0402	0	35,064	1,968	0.6376	-	40

BENGKULU	5	3	0.000E+00	0.0853	0.0423	0	33,814	2,636	0.6205	-	41
BENGKULU	5	4	1.111E-06	0.0852	0.0426	98	39,137	2,743	0.6564	-	41
BENGKULU	5	5	0.000E+00	0.0856	0.0428	0	38,552	3,293	0.7043	-	41
LAMPUNG	6	1	5.034E-05	0.0433	0.1326	1349	189,146	35,929	0.3881	10,539,953	15
LAMPUNG	6	2	8.197E-05	0.0429	0.1352	2372	91,833	15,595	0.2871	10,958,845	15
LAMPUNG	6	3	1.685E-04	0.0428	0.1333	4906	193,347	16,298	0.2672	11,394,384	16
LAMPUNG	6	4	1.710E-04	0.0450	0.1310	5030	214,688	16,06	0.2857	11,548,642	16
LAMPUNG	6	5	1.726E-04	0.0451	0.1308	5030	244,367	15,374	0.2908	12,588,801	17
BABEL	7	1	0.000E+00	0.0571	0.2706	0	-	-	0.0556	-	11
BABEL	7	2	7.270E-06	0.0552	0.2706	0	128,169	5,496	0.0556	-	12
BABEL	7	3	6.558E-06	0.0532	0.2660	64	136,841	5,867	0.0889	-	12
BABEL	7	4	5.395E-06	0.0509	0.2637	60	144,673	6,137	0.1586	-	13
BABEL	7	5	5.582E-06	0.0550	0.2641	61	144,797	14,667	0.1574	-	13
JAKARTA	8	1	6.604E-05	0.0008	0.1770	354	106,164	5,228	8.9659	33,862,267	5
JAKARTA	8	2	6.967E-05	0.0007	0.1757	155	108,737	8,772	10.3672	34,722,406	5
JAKARTA	8	3	4.796E-05	0.0006	0.1751	107	108,269	6,574	8.0863	35,604,394	6
JAKARTA	8	4	5.440E-05	0.0003	0.1747	120	127,054	33,698	9.5739	33,310,620	6
JAKARTA	8	5	5.514E-05	0.0003	0.1745	112	127,647	26,725	9.9108	36,073,714	6
WJAVA	9	1	2.070E-05	0.0074	0.3924	104	436,803	68,338	1.0361	-	75
WJAVA	9	2	2.747E-05	0.0079	0.3938	140	399,902	55,606	1.0361	-	76
WJAVA	9	3	3.749E-05	0.0082	0.3922	172	405,337	59,161	1.0309	-	76
WJAVA	9	4	3.531E-05	0.0081	0.4008	164	385,466	70,060	1.0363	-	77
WJAVA	9	5	3.031E-05	0.0073	0.3925	166	433,302	70,351	1.0427	-	77
CJAVA	10	1	8.912E-05	0.0073	0.2580	66	346,834	597	1.5352	1,743,013	83
CJAVA	10	2	8.773E-05	0.0074	0.2587	59	376,322	92,100	1.5764	1,841,327	84
CJAVA	10	3	1.678E-04	0.0077	0.2597	130	381,930	122,73	1.5808	1,945,187	84

CJAVA	10	4	8.882E-05	0.0077	0.2593	71	348,229	91,905	1.5777	1,883,520	85
CJAVA	10	5	7.810E-05	0.0075	0.2612	89	342,550	88,864	1.5777	1,986,801	85
YOGYA	11	1	3.743E-06	0.0138	0.1607	301	6,939	-	2.1428	-	18
YOGYA	11	2	0.000E+00	0.0147	0.1565	0	6,532	-	2.1428	-	18
YOGYA	11	3	0.000E+00	0.0142	0.1540	0	7,847	-	2.1277	-	19
YOGYA	11	4	1.564E-06	0.0133	0.1514	138	10,502	-	2.1277	-	19
YOGYA	11	5	1.578E-06	0.0129	0.1483	138	8,782	-	2.1780	-	19
EJAVA	12	1	3.306E-04	0.0027	0.2979	132	435,937	87,480	1.0600	8,251,787	71
EJAVA	12	2	2.908E-04	0.0030	0.2939	127	446,669	140,554	1.0600	8,735,403	71
EJAVA	12	3	2.602E-04	0.0034	0.2811	116	554,084	178,869	1.0760	9,247,362	72
EJAVA	12	4	2.506E-04	0.0035	0.2802	136	576,945	176,641	1.0753	8,905,982	72
EJAVA	12	5	2.578E-04	0.0036	0.2788	140	490,669	112,022	1.0625	11,436,695	73
BANTEN	13	1	0.000E+00	0.0138	0.5264	0	-	-	0.0635	-	20
BANTEN	13	2	2.005E-06	0.0140	0.5259	0	129,741	-	0.0635	-	20
BANTEN	13	3	1.991E-06	0.0146	0.5224	174	87,835	14,174	0.1899	-	21
BANTEN	13	4	1.972E-06	0.0148	0.5174	174	81,889	12,500	0.2171	-	22
BANTEN	13	5	1.990E-06	0.0156	0.5130	174	76,438	12,087	0.2364	-	22
BALI	14	1	2.843E-05	0.0300	0.0923	229	166,502	5,601	9.6939	521,452	10
BALI	14	2	2.032E-05	0.0291	0.0938	147	168,755	17,287	10.0276	427,849	11
BALI	14	3	2.157E-05	0.0368	0.0955	145	196,356	21,196	10.0469	351,048	11
BALI	14	4	2.154E-05	0.0411	0.0966	173	210,456	23,370	10.0592	168,802	12
BALI	14	5	2.075E-05	0.0411	0.0958	202	227,082	21,377	10.0821	208,378	12
ENT	15	1	6.342E-07	0.0386	0.0165	51	94,843	20,137	0.4607	706,893	11
ENT	15	2	9.447E-07	0.0384	0.0164	41	106,178	18,177	0.4607	673,950	11
ENT	15	3	8.011E-07	0.0383	0.0163	70	116,262	16,982	0.4592	642,542	12

ENT	15	4	1.043E-06	0.0378	0.0164	46	102,276	16,128	0.4587	500,865	12
ENT	15	5	2.482E-06	0.0379	0.0162	54	163,698	18,380	0.4581	544,435	12
WKAL	16	1	7.648E-06	0.0217	0.2415	103	81,063	11,862	0.1412	8,360,905	63
WKAL	16	2	8.065E-06	0.0214	0.2279	117	80,459	18,037	0.1412	9,683,995	64
WKAL	16	3	8.011E-06	0.0210	0.2178	117	80,947	15,855	0.1421	11,216,460	64
WKAL	16	4	8.683E-06	0.0211	0.2072	128	79,449	13,689	0.1400	14,466,505	64
WKAL	16	5	6.646E-06	0.0207	0.2018	116	80,245	13,729	0.1362	14,397,395	65
CKAL	17	1	1.306E-06	0.0601	0.0994	105	91,339	24,919	0.0790	-	4
CKAL	17	2	1.279E-06	0.0654	0.0931	111	93,707	23,741	0.0790	-	4
CKAL	17	3	1.270E-06	0.0603	0.0902	111	95,278	24,820	0.0762	-	5
CKAL	17	4	1.338E-06	0.0605	0.0913	118	78,751	13,578	0.0765	-	5
CKAL	17	5	1.350E-06	0.0612	0.0935	118	78,170	16,859	0.0772	-	5
SKAL	18	1	1.450E-05	0.0475	0.1724	194	161,496	39,805	0.2733	8,784,892	2
SKAL	18	2	2.204E-05	0.0463	0.1655	273	163,430	34,170	0.2733	10,719,860	3
SKAL	18	3	2.108E-05	0.0450	0.1586	307	169,424	39,452	0.2762	13,081,026	3
SKAL	18	4	1.715E-05	0.0432	0.1527	303	173,619	50,953	0.2759	17,477,039	3
SKAL	18	5	2.105E-05	0.0414	0.1474	263	173,721	49,458	0.2757	20,748,996	4
EKAL	19	1	3.208E-05	0.0118	0.0550	287	121,121	17,477	0.1965	145,994,445	12
EKAL	19	2	4.730E-05	0.0118	0.0510	373	134,227	14,285	0.1965	124,574,725	13
EKAL	19	3	5.062E-05	0.0122	0.0509	402	134,149	19,168	0.1946	106,297,620	14
EKAL	19	4	4.711E-05	0.0128	0.0513	346	136,908	23,731	0.1986	65,161,149	15
EKAL	19	5	5.512E-05	0.0139	0.0513	371	168,493	14,538	0.1993	57,997,113	15
NSUL	20	1	3.942E-05	0.0491	0.0830	186	203,500	60,348	0.7845	3,297,015	13
NSUL	20	2	5.672E-05	0.0435	0.0829	328	198,884	53,806	0.7845	3,444,288	14
NSUL	20	3	5.127E-05	0.0441	0.0813	249	212,946	71,758	0.8365	3,598,139	14
NSUL	20	4	3.617E-05	0.0453	0.0809	245	207,009	94,591	0.8195	3,420,482	15

NSUL	20	5	4.342E-05	0.0471	0.0776	271	213,221	75,519	0.7442	3,699,293	16
CSUL	21	1	5.596E-07	0.0423	0.1239	45	16,437	29,392	0.1919	-	8
CSUL	21	2	5.184E-07	0.0450	0.1018	45	103,475	19,233	0.1919	-	8
CSUL	21	3	4.921E-07	0.0461	0.1009	43	91,473	15,967	0.1810	-	9
CSUL	21	4	0.000E+00	0.0438	0.0991	0	106,179	11,933	0.1826	-	9
CSUL	21	5	0.000E+00	0.0423	0.0984	0	109,923	15,292	0.1942	-	9
SSUL	22	1	4.892E-05	0.0671	0.1297	219	468,392	61,473	0.6463	6,216,514	7
SSUL	22	2	4.590E-05	0.0671	0.1305	221	469,747	60,611	0.6463	6,792,920	7
SSUL	22	3	5.274E-05	0.0667	0.1291	230	681,176	64,974	0.6395	7,422,772	8
SSUL	22	4	5.579E-05	0.0666	0.1323	224	511,873	73,001	0.6414	8,278,474	8
SSUL	22	5	5.093E-05	0.0684	0.1336	223	488,519	52,094	0.6529	8,964,875	8
SESUL	23	1	4.202E-05	0.0797	0.0107	375	166,675	24,996	0.8109	-	47
SESUL	23	2	3.620E-05	0.0772	0.0112	224	183,498	39,178	0.8109	-	48
SESUL	23	3	2.859E-05	0.0795	0.0112	125	194,969	42,589	0.8023	-	48
SESUL	23	4	2.603E-05	0.0727	0.0114	109	213,092	36,603	0.8047	-	48
SESUL	23	5	2.638E-05	0.0701	0.0132	110	290,604	43,810	0.8192	-	49
GORON	24	1	0.000E+00	0.0987	0.1239	0	-	-	0.0385	-	32
GORON	24	2	1.659E-06	0.1003	0.1018	0	34,096	4,247	0.0385	-	33
GORON	24	3	3.033E-06	0.0998	0.1009	44	38,029	7,297	0.1063	-	33
GORON	24	4	4.795E-06	0.0953	0.0991	53	40,312	3,989	0.1077	-	34
GORON	24	5	5.868E-06	0.0978	0.0984	64	43,28	789	0.1237	-	34
MALUKU	25	1	5.248E-06	0.1701	0.0541	70	362,468	122,131	0.1767	199,700	5
MALUKU	25	2	2.696E-06	0.1578	0.0503	47	218,885	98,430	0.1767	231,314	5
MALUKU	25	3	2.678E-06	0.1572	0.0490	47	171,798	99,386	0.1641	267,933	6
MALUKU	25	4	5.214E-06	0.1545	0.0479	66	373,882	287,578	0.1718	306,621	7
MALUKU	25	5	5.262E-06	0.1528	0.0474	66	428,210	342,466	0.1747	334,082	7

NMALUKU	26	1	2.611E-07	0.0492	0.1575	21	-	-	0.0172	-	2
NMALUKU	26	2	2.765E-07	0.0491	0.1565	24	84,643	29,458	0.0172	-	2
NMALUKU	26	3	2.747E-07	0.0490	0.1585	24	105,260	38,090	0.0279	-	3
NMALUKU	26	4	0.000E+00	0.0484	0.1552	0	77,951	32,080	0.0381	-	3
NMALUKU	26	5	0.000E+00	0.0478	0.1554	0	80,643	15,723	0.0396	-	3
PAPUA	27	1	4.718E-05	0.0404	0.0304	5454	209,319	289,760	0.1514	325,106	12
PAPUA	27	2	4.371E-05	0.0379	0.0291	5495	214,380	131,671	0.1514	505,394	12
PAPUA	27	3	4.342E-05	0.0375	0.0328	17800	220,762	107,790	0.1461	785,662	12
PAPUA	27	4	4.301E-05	0.0415	0.0358	27282	249,465	150,721	0.1538	893,397	13
PAPUA	27	5	4.340E-05	0.0486	0.0370	40797	281,702	163,350	0.1571	2,797,417	13